

OMF

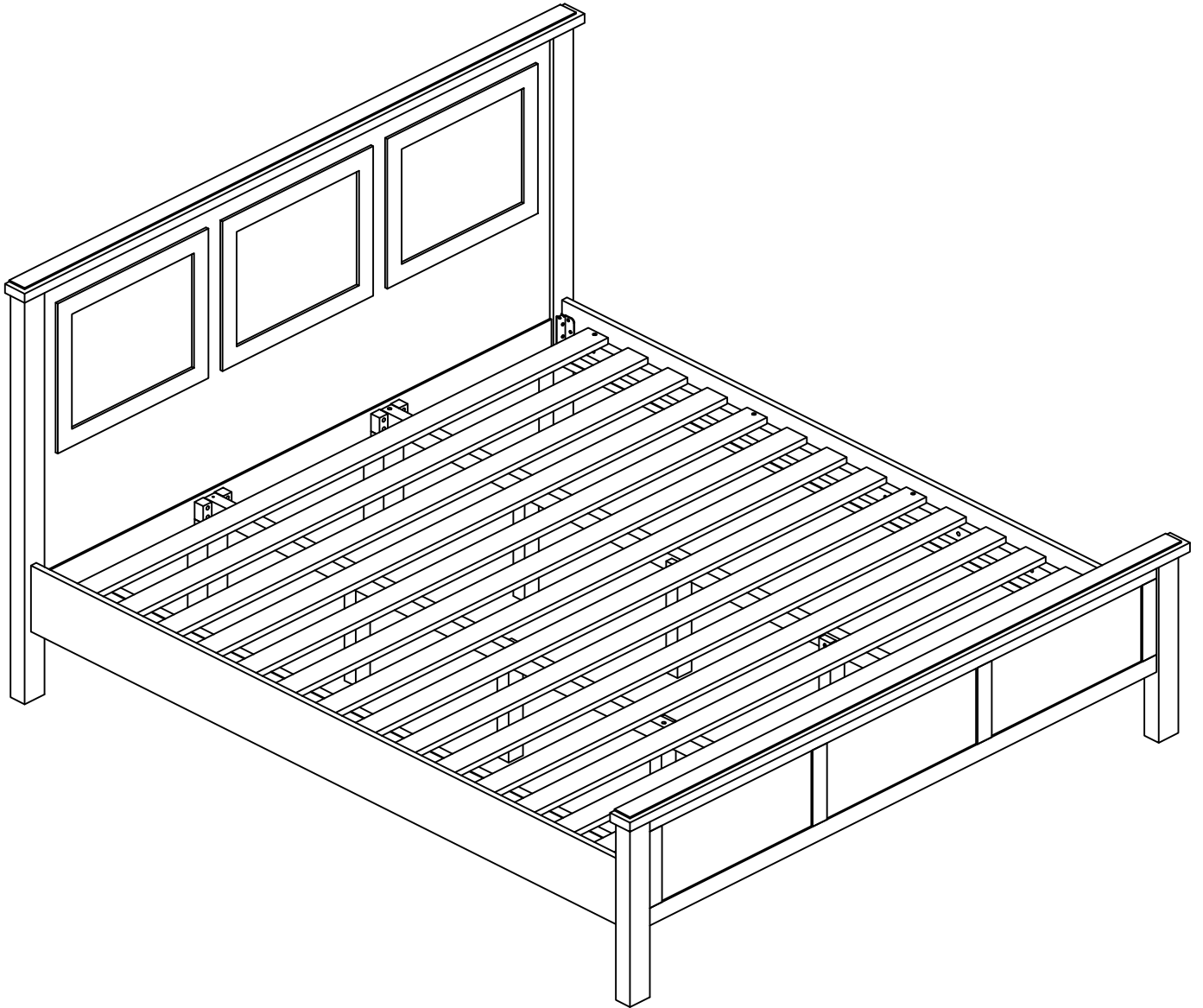

TWO PEOPLE

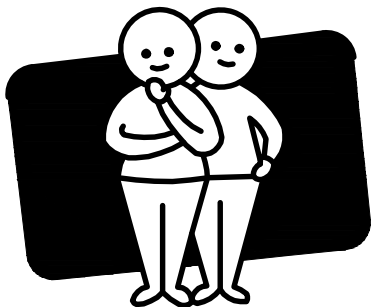

REQUIRED

HAMPTONS KING BED

Enjoy

Your purchase From

OML

Assembly checklist



Read through the instructions carefully before you begin.



Make sure you have all the required tools. Never use power tools unless instructed.



Identify and lay out all of the components before you begin assembly.

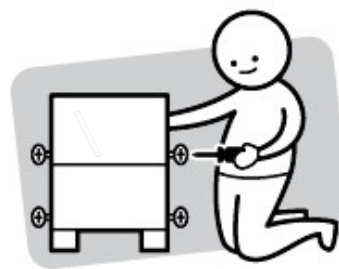

Unless instructed, do not fully tighten screws until the item is fully assembled.

Useful Information

- ! Never use power tools unless specifically instructed. They can damage your components or hardware if used incorrectly.
- ! The most common mistakes made during assembly are using the wrong hardware or getting components back to front.
- ! Always use a soft surface (such as carpet or cardboard) when assembling your product to avoid scratching or damaging the surface of the product.
- ! Bulky items such as wardrobes and bunk beds should be assembled in the room they will be used in as they may not fit through a door once assembled.
- ! Never use any glue until you are certain that the parts belong together.
- ! Periodically check and re-tighten all fasteners. Check the product care label or website for product care instructions.
- ! If you are having any difficulties assembling your product, missing any hardware or components please visit our website Help Centre for further assistance.

What you need

to assemble the product



DO NOT USE



Other tools you need
Phillips head screwdriver

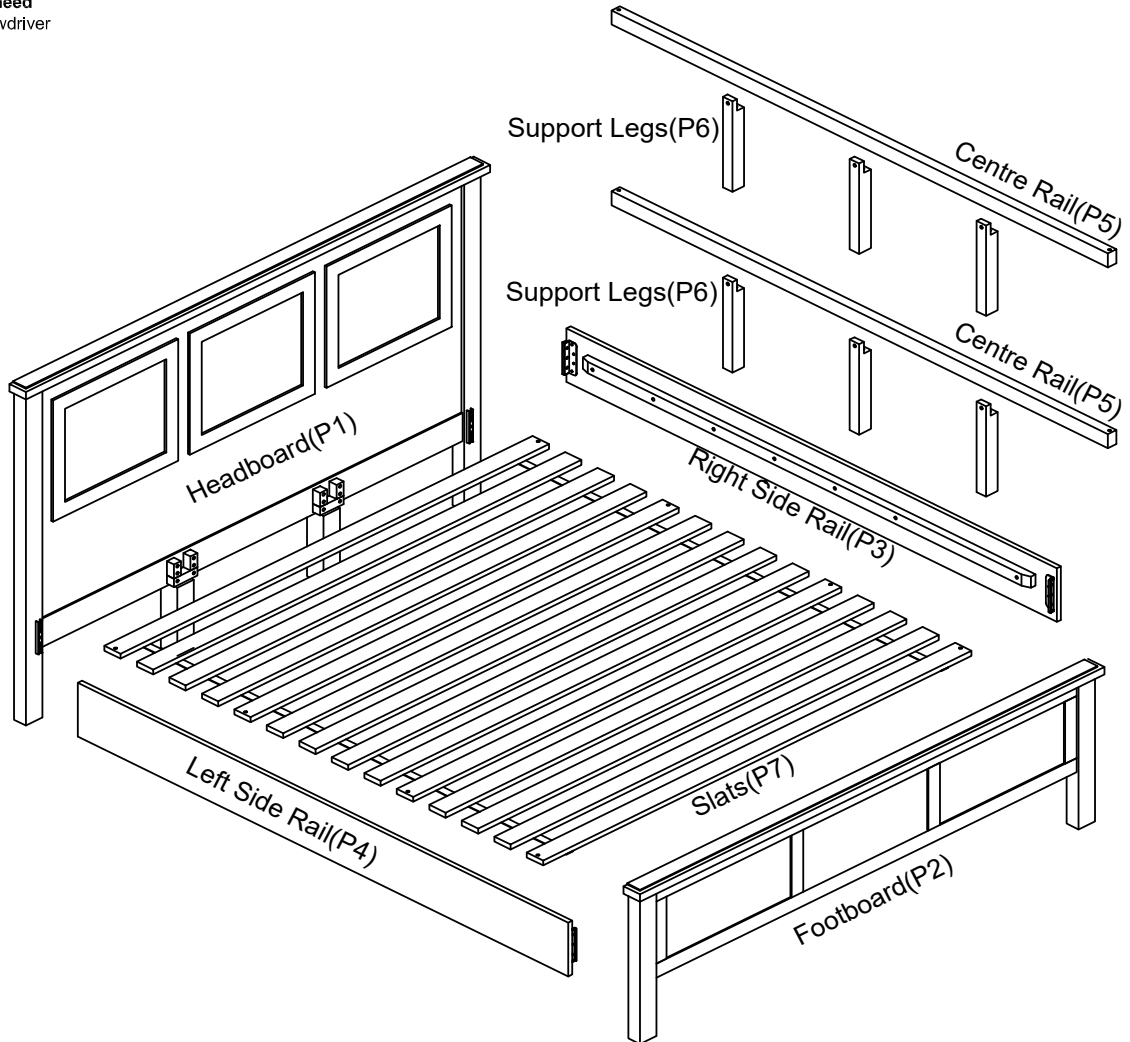

Parts list

Box 1 : Headboard(P1) ; Footboard(P2)

Box 2 : Right Side Rail(P3) ; Left Side Rail(P4) ; Centre Rail(P5) ; Support Legs(P6) ; Hardware Pack

Box 3 : Slats(P7)



(Gold Bolts)
8 x M8 x 18mm
(H1)



(Allen Key)
1 x M5
(H2)



(Long Screws)
4 x M4 x 50mm
(H3)





(Short Screws)
14 x M4 x 35mm
(H4)



(Dowel Ø10)
6 x Ø10 x 30mm
(H5)

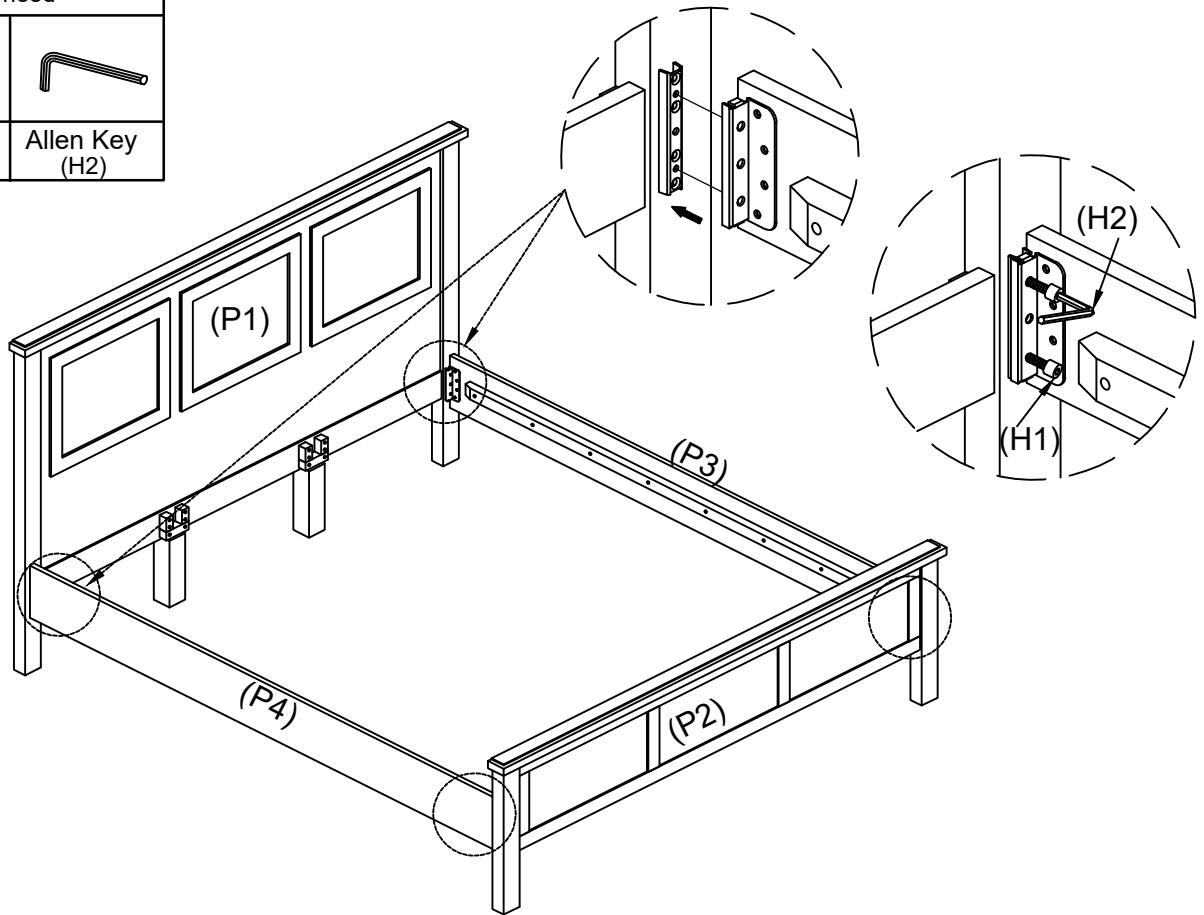

Step 1

You will need	
	
8 x Bolts 18mm (H1)	Allen Key (H2)



Attach side rails (P3) / (P4) to headboard (P1) and footboard (P2) by install 8 x bolts (H1) to the brackets of the headboard (P1) and footboard (P2) by using allen key (H2) as shown.No need to tighten bolts until step 4.

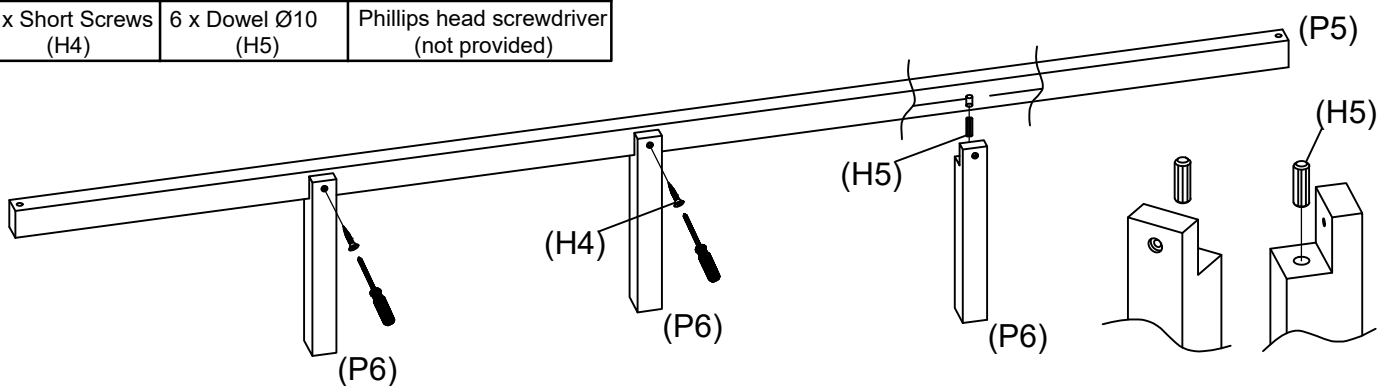

Step 2

You will need		
		
6 x Short Screws (H4)	6 x Dowel Ø10 (H5)	Phillips head screwdriver (not provided)



Attach the support legs (P6) to the centre rail (P5) using 6 x dowel Ø10 (H5) + 6 x short screws (H4) by using phillips head screwdriver as shown .

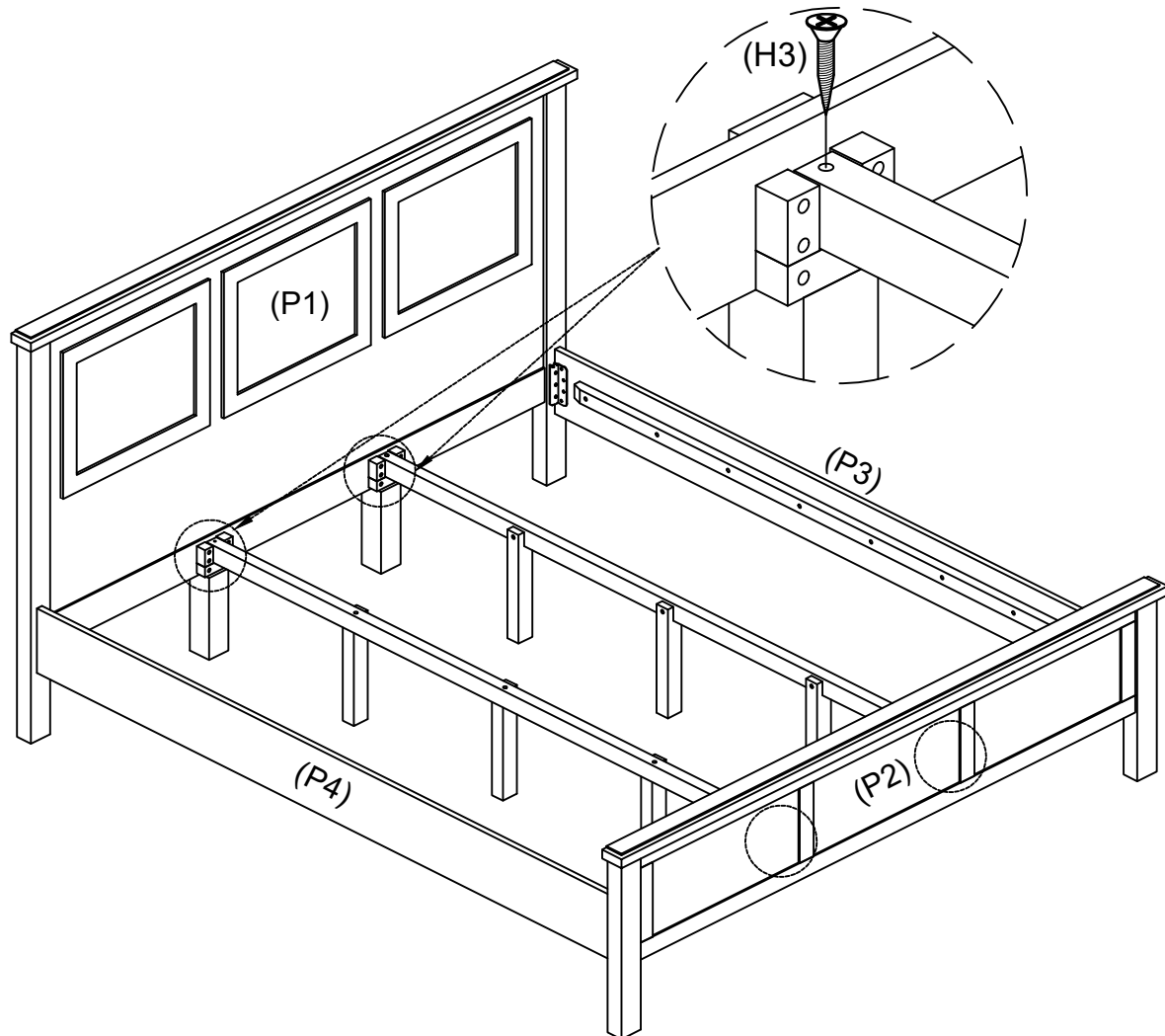

Step 3

You will need	
	
4 x Long Screws (H3)	Phillips head screwdriver (not provided)



Attach 2 centre rails (P5) into the headboard (P1) and footboard (P2), then assemble them using 4 x long screws(H3) screwing them into the headboard (P1) and footboard (P2)

Step 4

You will need	
	
8 x Short Screws (H4)	Phillips head screwdriver (not provided)

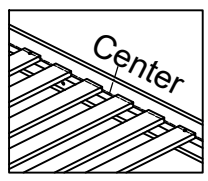
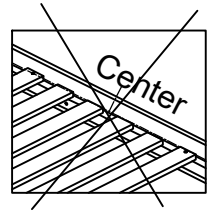
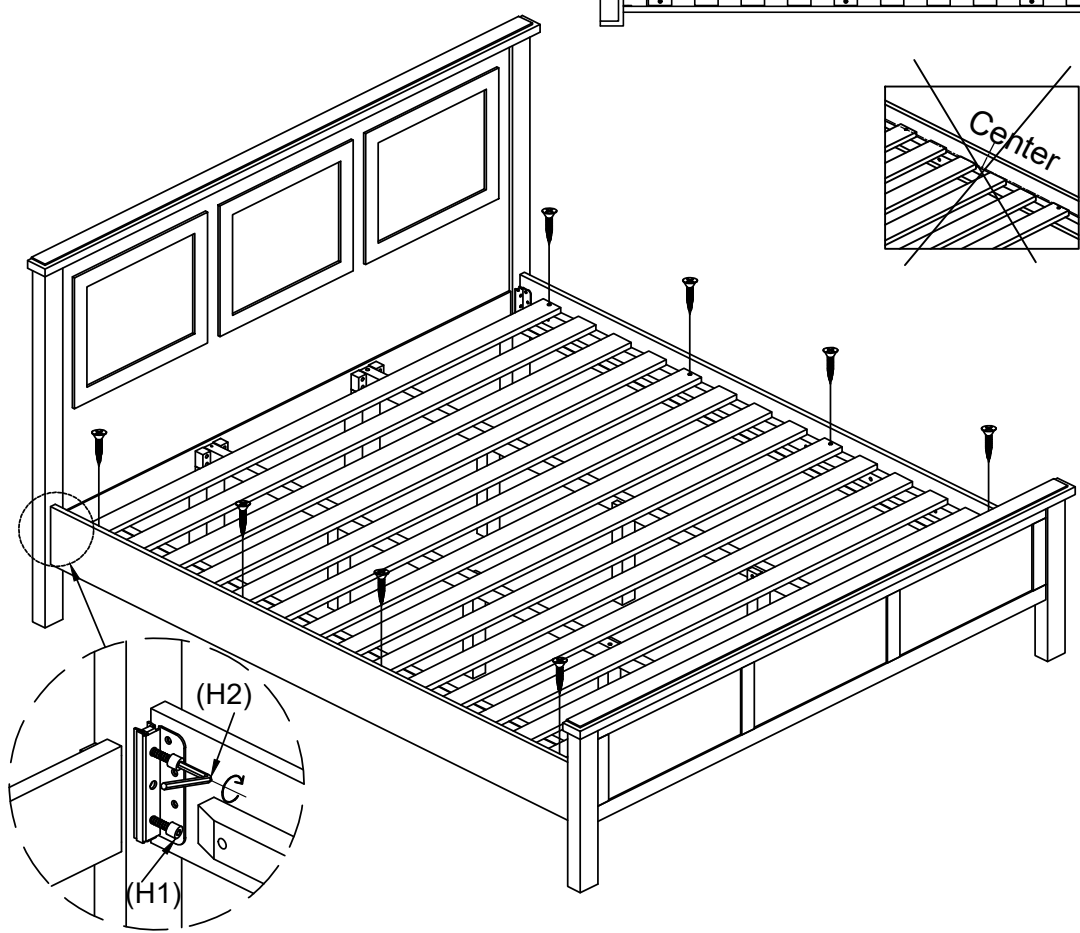
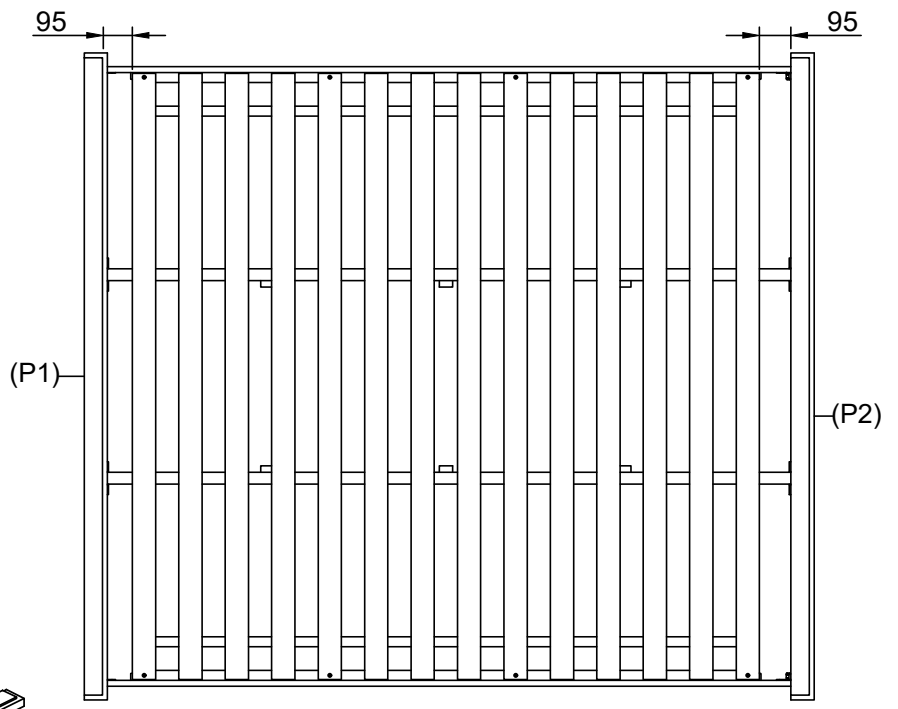

Make sure the inner space is balance.
 Now tighten all the bolts on the corner bracket and tighten bolts on the headboard(P1), footboard(P2), and side rail (P3/P4). Then assemble all the slats(P7) down by using 8 x short screws(H4). Adjust the slats to the center before screwing them onto the bed frame.

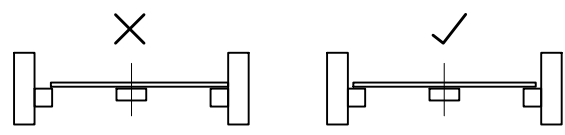

Step 5

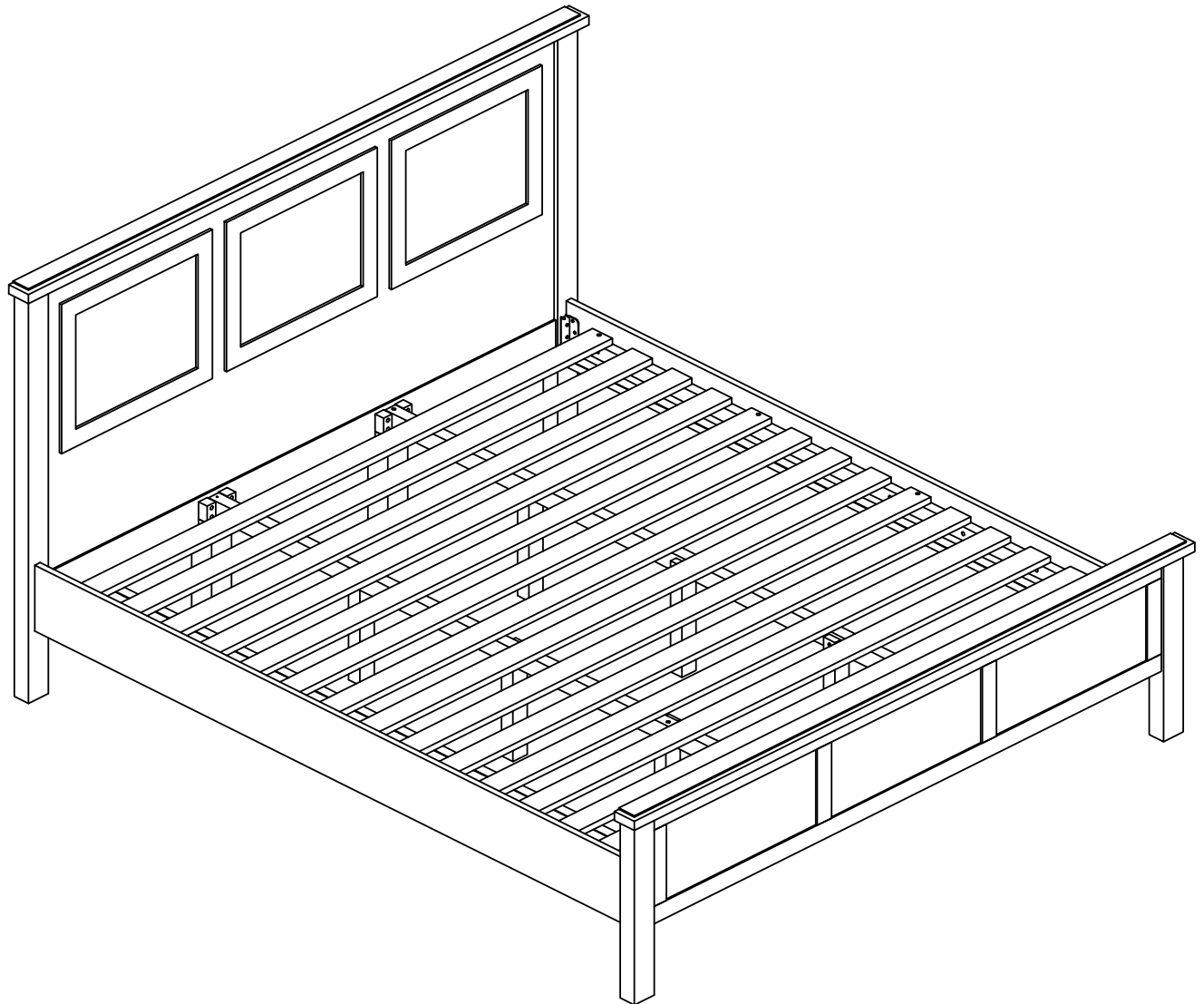

Job Complete

In the interest of our environment please dispose of all packaging thoughtfully.