

OMF

Version 1.1

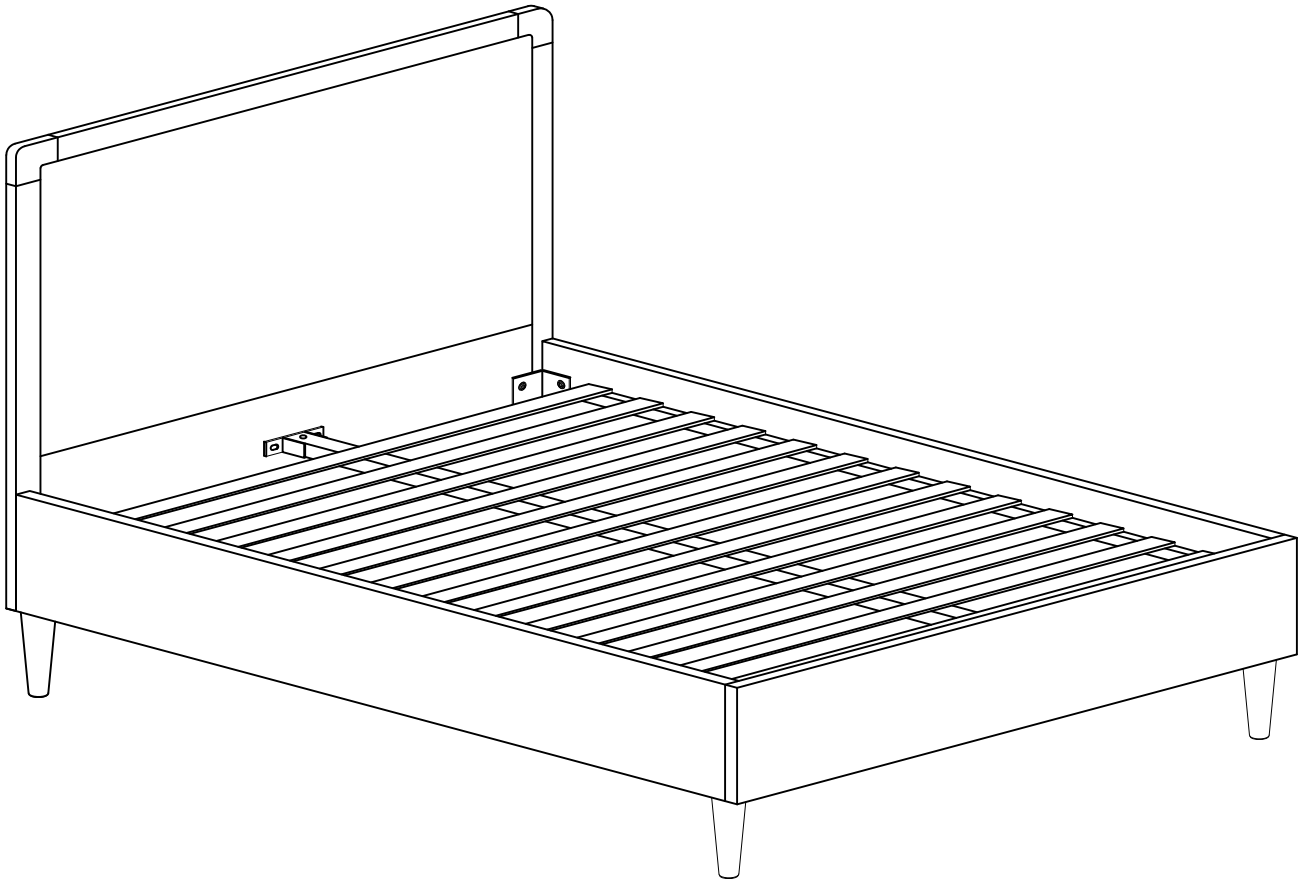

TWO PEOPLE

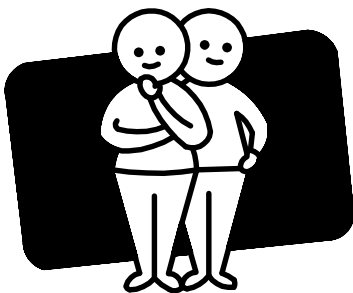

REQUIRED

LOFT

Double Bed

Enjoy
Your purchase From

OML

Assembly checklist



Read through the instructions carefully before you begin.



Make sure you have all the required tools. Never use power tools unless instructed.

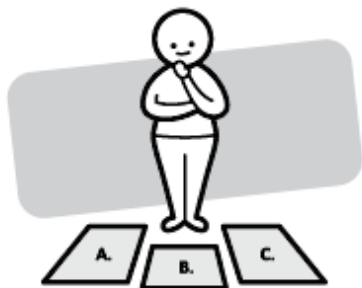

Identify and lay out all of the components before you begin assembly.

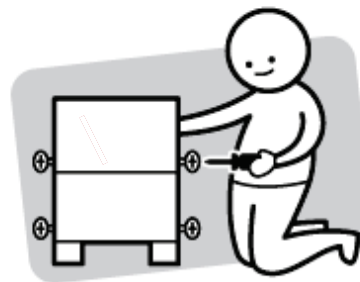

Unless instructed, do not fully tighten screws until the item is fully assembled.

Useful Information

- ! Never use power tools unless specifically instructed. They can damage your components or hardware if used incorrectly.
- ! The most common mistakes made during assembly are using the wrong hardware or getting components back to front.
- ! Always use a soft surface (such as carpet or cardboard) when assembling your product to avoid scratching or damaging the surface of the product.
- ! Bulky items such as wardrobes and bunk beds should be assembled in the room they will be used in as they may not fit through a door once assembled.
- ! Never use any glue until you are certain that the parts belong together.
- ! Periodically check and re-tighten all fasteners. Check the product care label or website for product care instructions.
- ! If you are having any difficulties assembling your product, missing any hardware or components please visit our website Help Centre for further assistance.

What you need to assemble the product

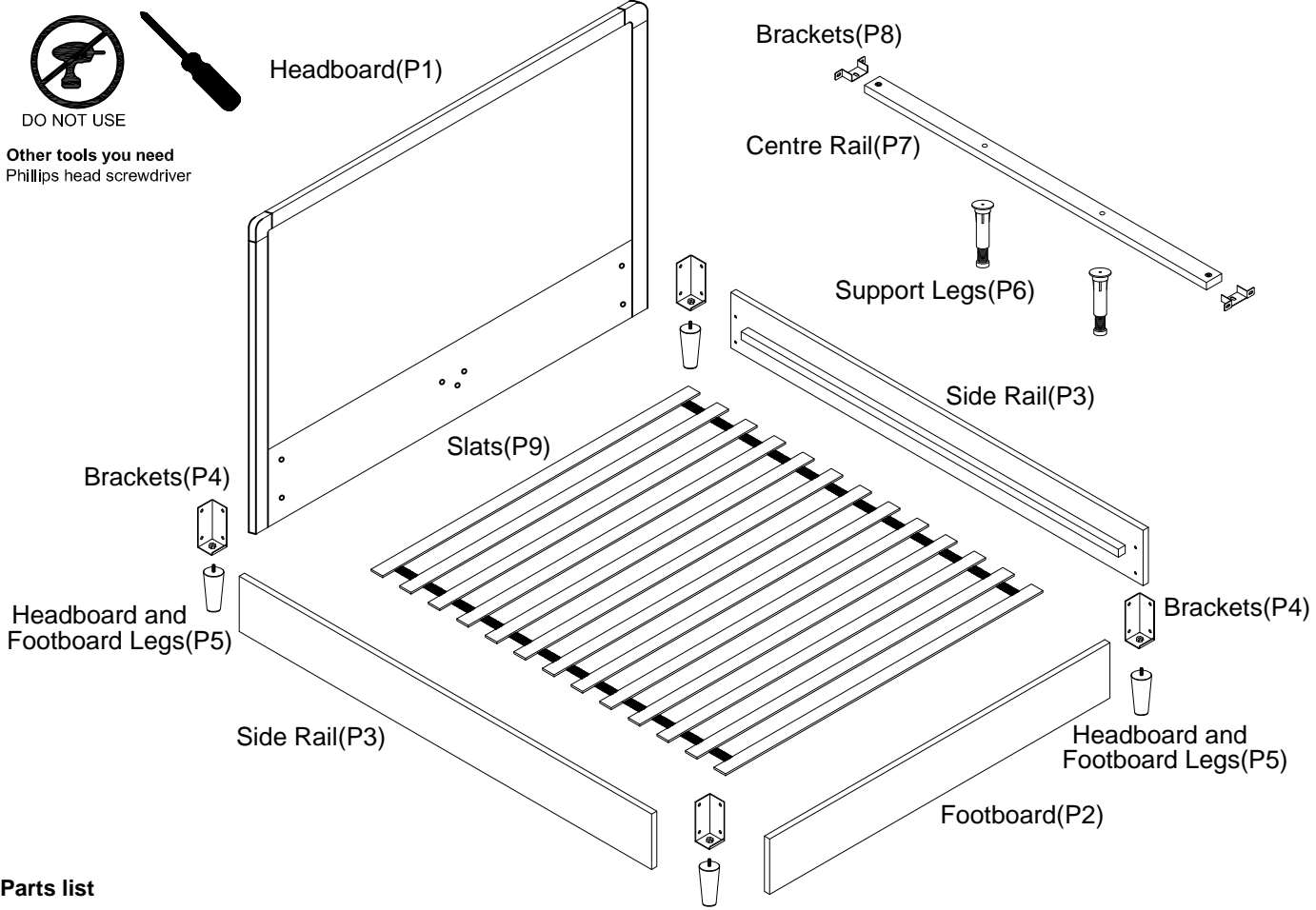





Parts list

Box 1 : Footboard(P2) ; Side Rail(P3) ; Brackets(P4) ;

Headboard/Footboard Legs(P5) ; Support Legs(P6) ; Centre Rail(P7) ; Brackets(P8) ; Hardware Pack

Box 2 : Headboard(P1)

Box 3 : Slats(P9)

| | | |
|---|---|---|
|  |  |  |
| (Small Bolts) 18 x M8 x 15mm (H1) | (Allen Key) 1 x M5 (H2) | (Medium Bolts) 6 x M8 x 35mm (H3) |
|  |  | |
| (Washers) 24 x M8 x 19mm (H4) | (Screws) 39 x M4 x 32mm (H5) | |



Please make sure you have all these parts before you start

Step 1

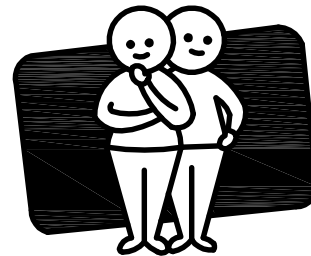
TWO PEOPLE



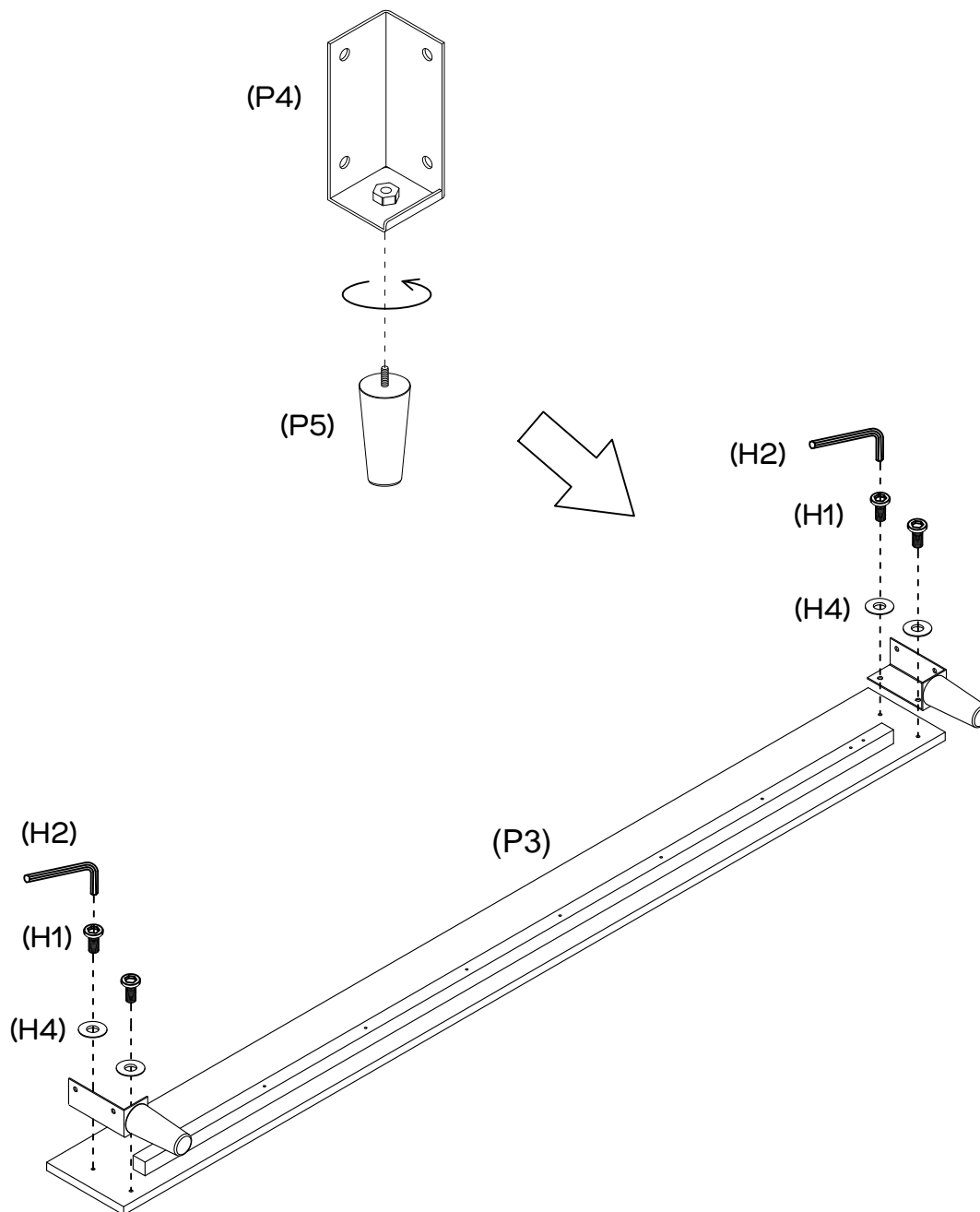

RED

| You will need | | |
|---|---|---|
|  |  |  |
| 8 x Small Bolts 15mm (H1) | Allen Key (H2) | 8 x Washers M8 (H4) |



Attach 4 x legs (P5) to the bottom of leg brackets (P4), rotate the legs until they are fully tightened. Then, attach leg brackets (P4) to the side rails (P3) with 8 x washers (H4) and 8 x bolts (H1) by using the allen key (H2). Please do not tighten all the bolts until Step 7.

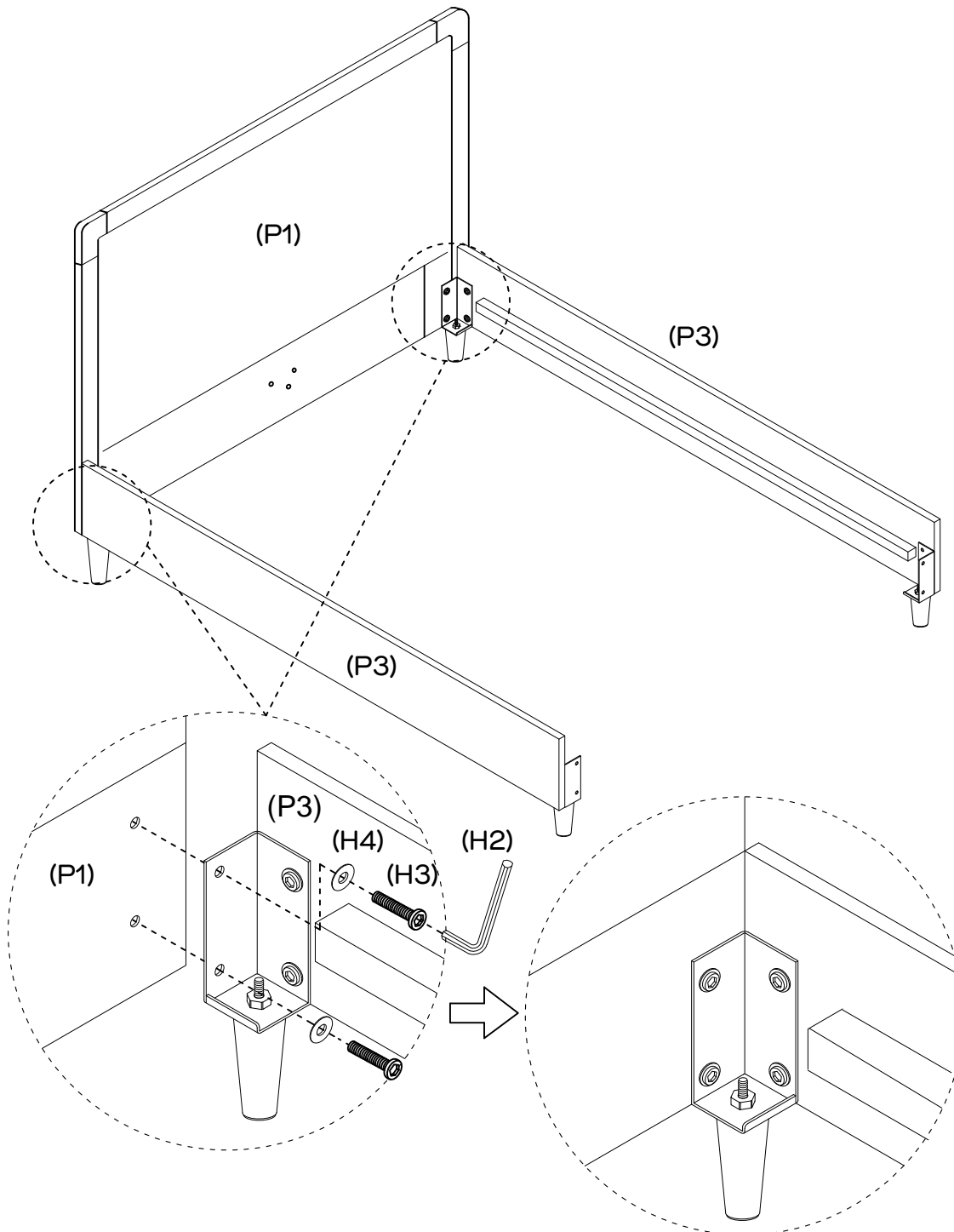

Step 2

| You will need | | |
|---|---|---|
|  |  |  |
| Allen Key (H2) | 4 x Medium Bolts 35mm (H3) | 4 x Washers M8 (H4) |



Attach 2 x side rails (P3) to the headboard (P1) with 4 x medium bolts (H3) and 4 x washers (H4) by using allen key (H2).
Please do not tighten bolts until Step 7.



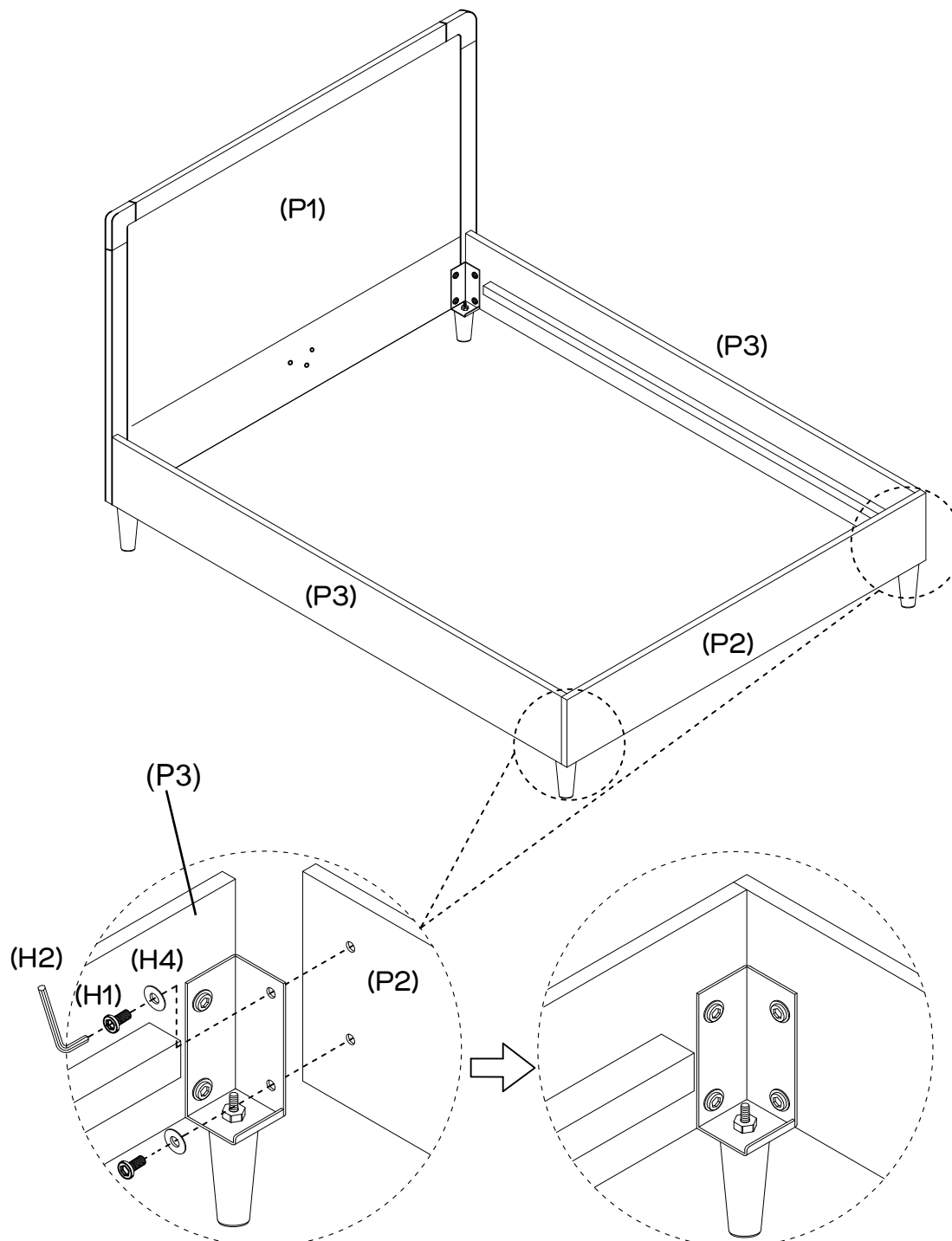

Step 3

| You will need | | |
|---|---|---|
|  |  |  |
| 4 x Small Bolts 15mm (H1) | Allen Key (H2) | 4 x Washers M8 (H4) |

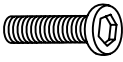

Attach the footboard (P2) to the side rails (P3) with 4 x small bolts (H1) and 4 x washers (H4) by using allen key (H2).
Please do not tighten bolts until Step 7.

Step 4

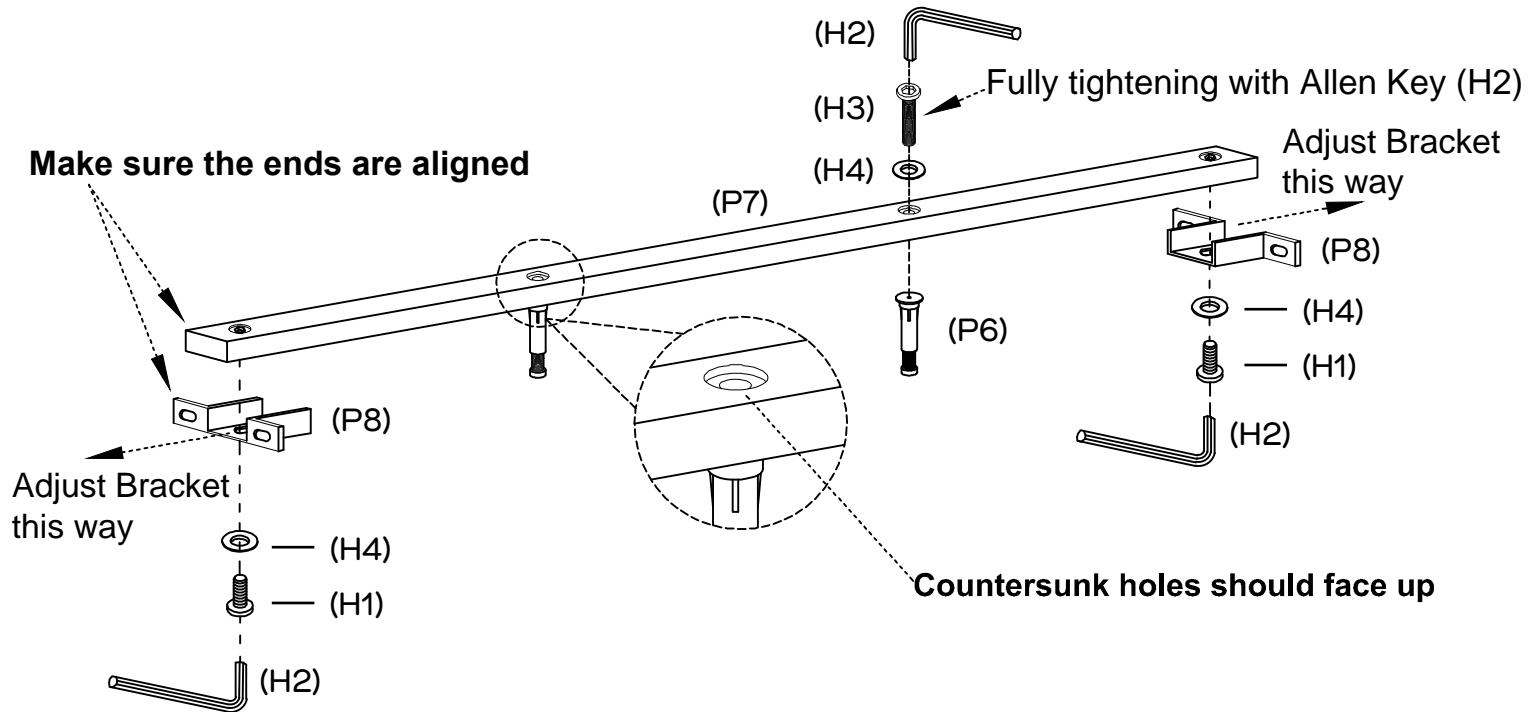

| You will need | | | |
|---|---|---|---|
|  |  |  |  |
| 2 x Small Bolts 15mm (H1) | Allen Key (H2) | 2 x Medium Bolts 35mm (H3) | 4 x Washers M8 (H4) |



Attach the support legs (P6) to the centre rail (P7) with 2 x medium Bolts (H3) and 2 x washers (H4) by using allen key (H2).

Attach 2 x bracket (P8) to the centre rail (P7) with 2 x small bolts (H1) and 2 x washers (H4) by using allen key (H2) as shown.

Step 5

| You will need | | |
|---|---|---|
|  |  |  |
| 4 x Small Bolts 15mm (H1) | Allen Key (H2) | 4 x Washers M8 (H4) |

You must use.

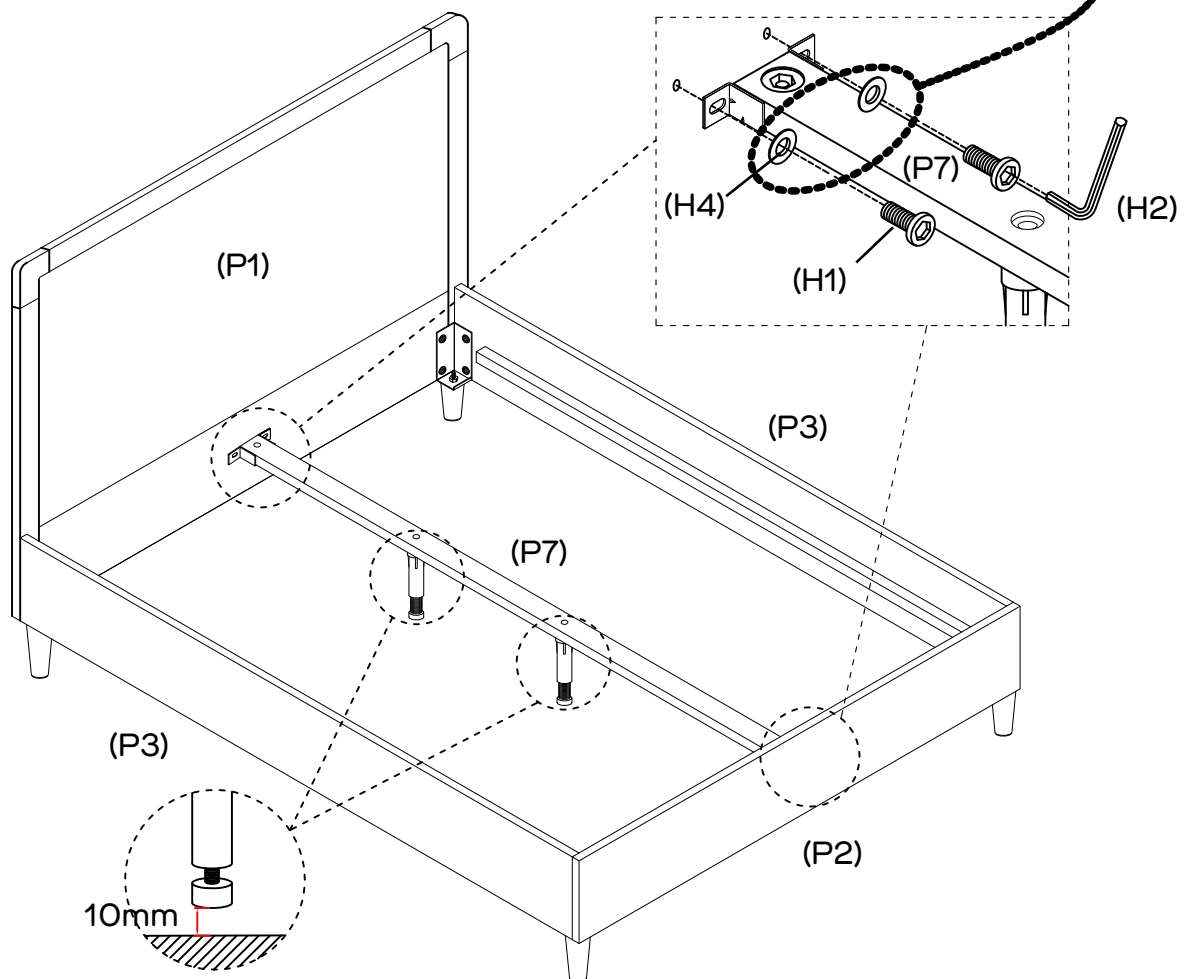

Adjust so there is a 10mm gap between the floor and the bottom of the support legs.

Slot the centre rail (P7) into the headboard (P1) and footboard (P2). Rotate 4 x small bolts (H1) and 4 x washers (H4) by using allen key (H2) to the headboard (P1) and footboard (P2). Fully tighten all the small bolts (H1).

Step 6

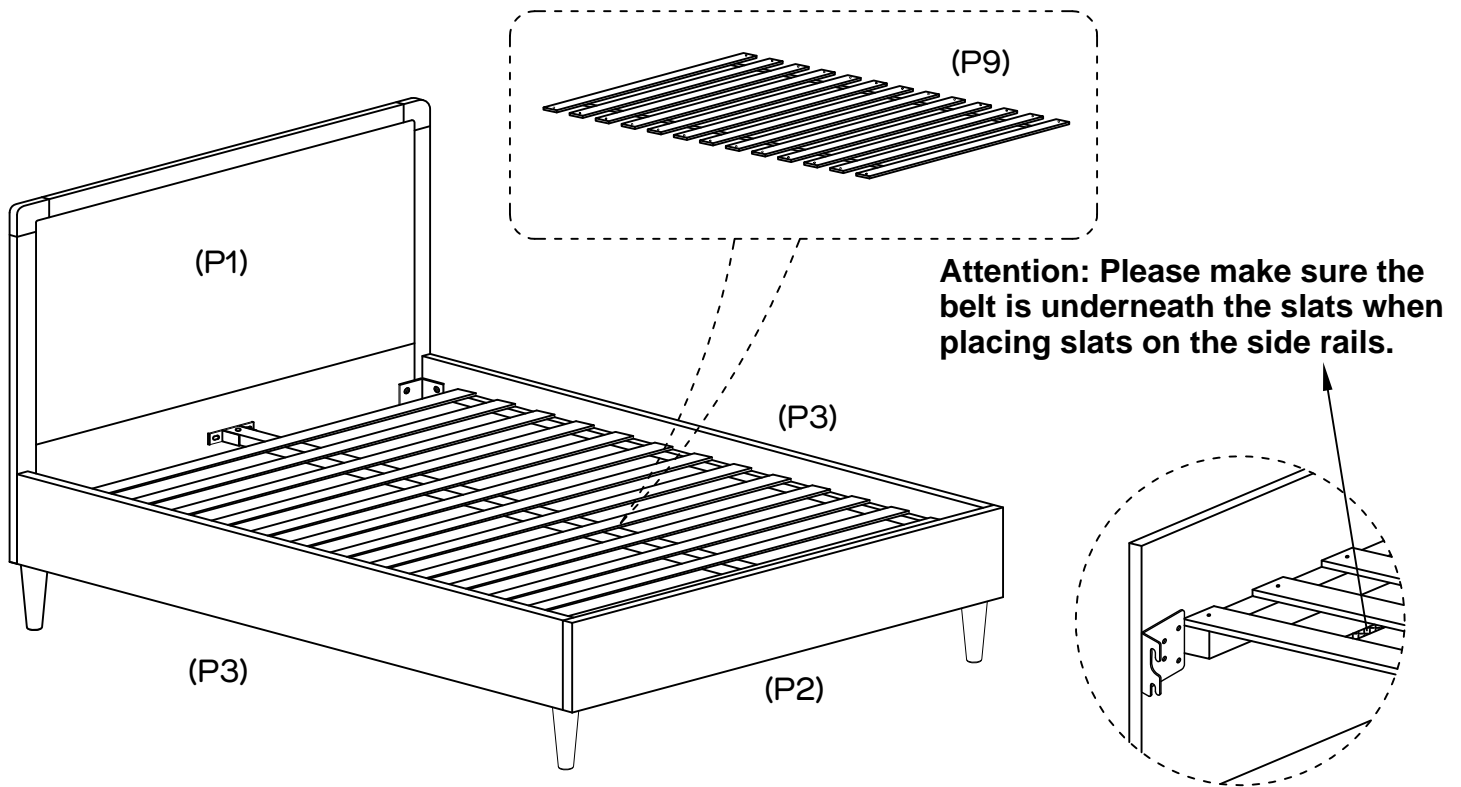

Ensure the bed inner space is square and even as shown above.
Place the Slats (P9) onto the assembled bed frame as shown.

Step 7

You will need



Allen Key
(H2)

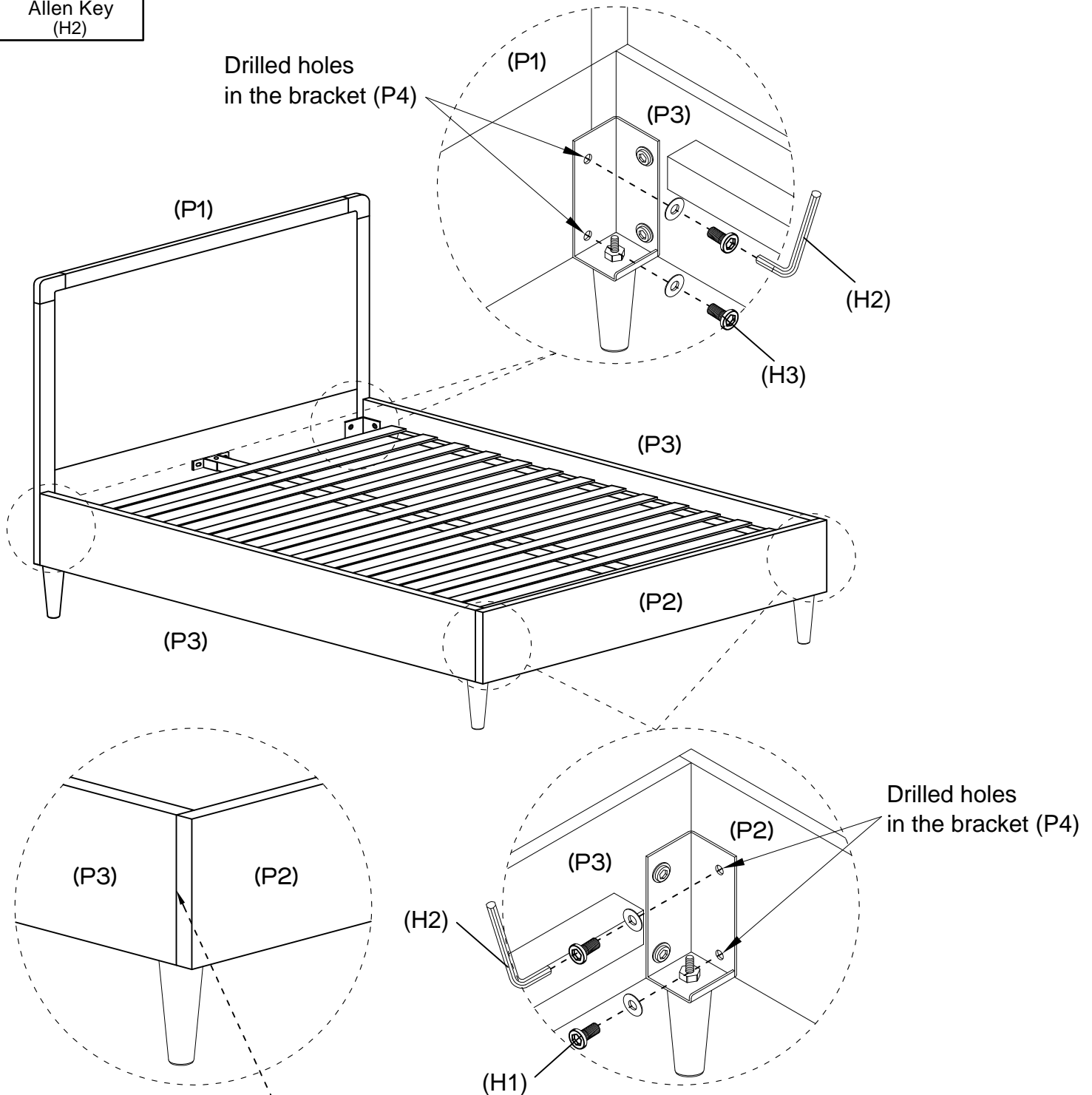

Make sure they are aligned

Fully tighten all the small bolts (H1) and medium bolts (H3) on the headboard (P1), footboard (P2) and side rails (P3).

Attention:

The drilled holes in the Brackets (P4) is a little bigger than the Bolts (H1/H3), when assembling, the Bolts (H1/H3) can be adjusted to make sure side rails and footboard are aligned.

Step 8

You will need



4 x Screws
(H5)

Phillips Head
Screwdriver
(not provided)

(P1)

(P2)

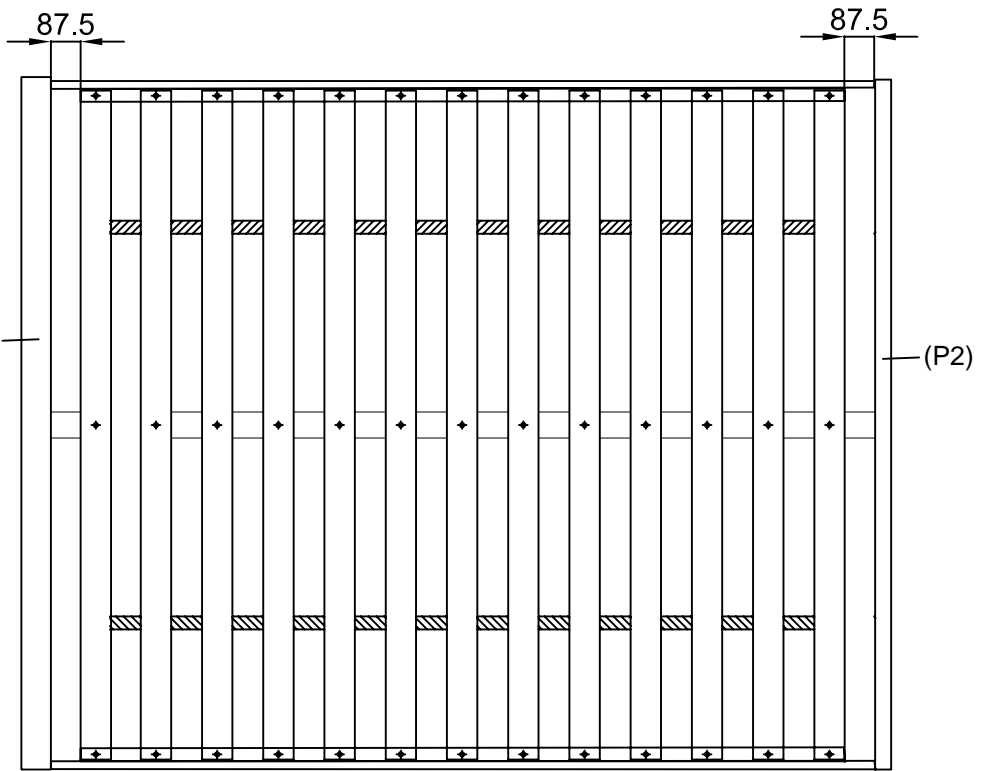

Make sure the screws are in the centre of side rail cleat.

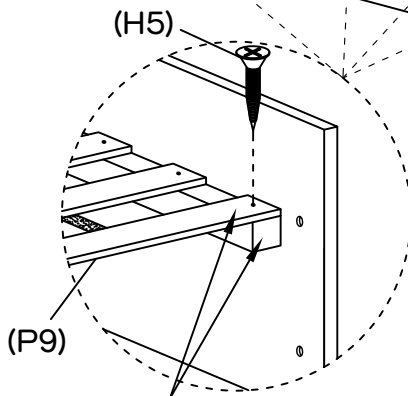
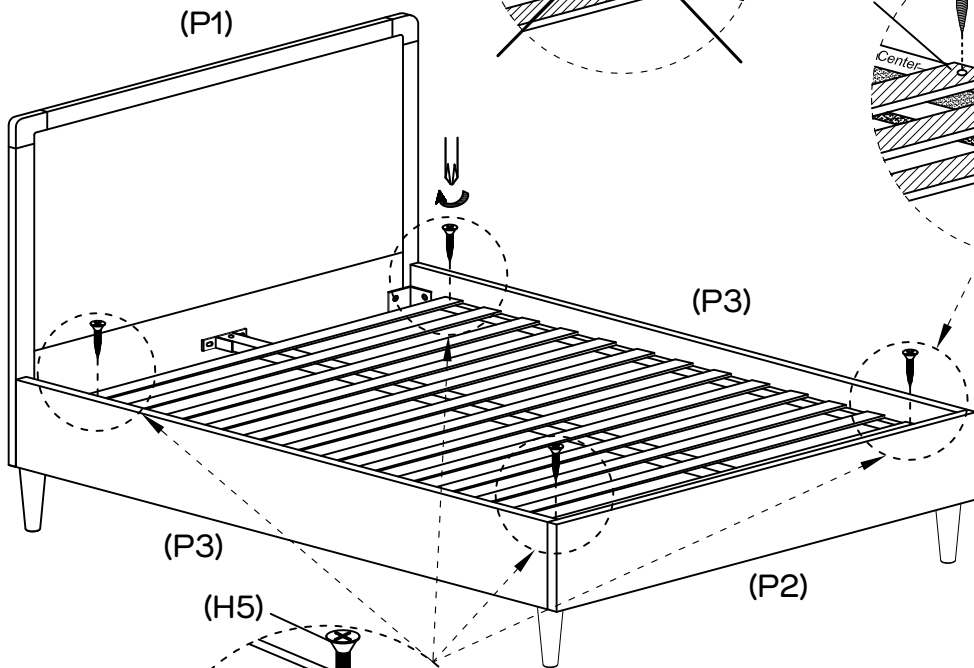
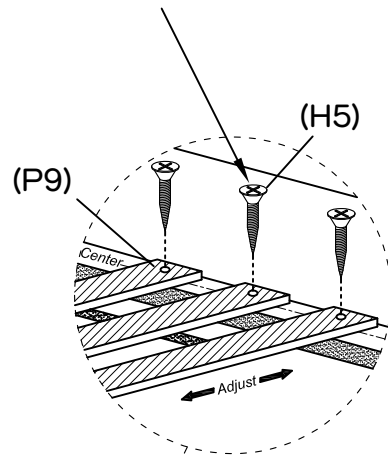
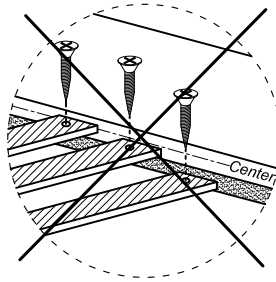

Attach the Slats (P9) to the assembled frame using 4 x Screws (H5) as shown. Ensure the slats are centred before screwing them to the bed frame.

Make sure the two ends are aligned.

Step 9

You will need



35 x Screws
(H5)



Phillips Head
Screwdriver
(not provided)

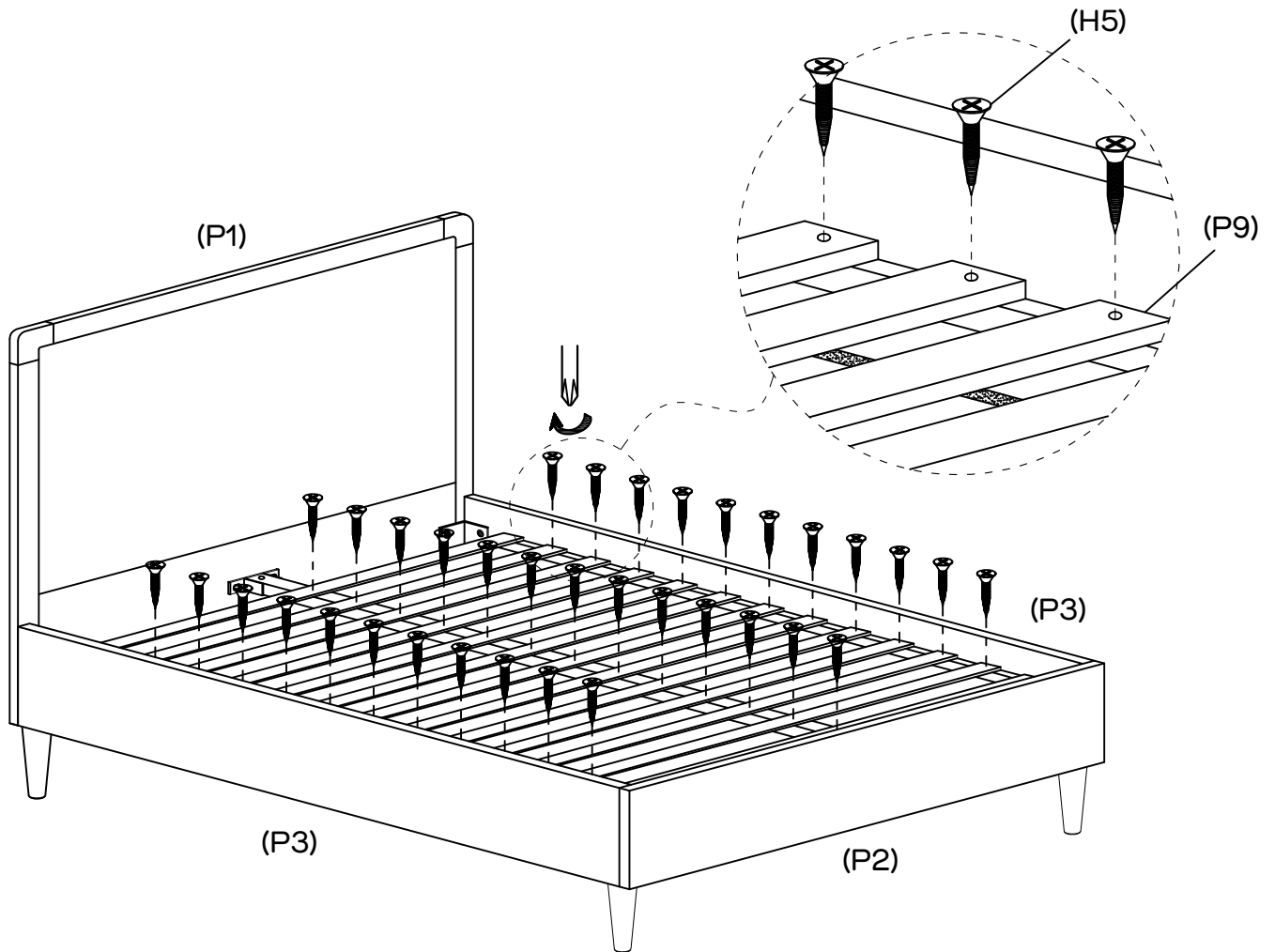

Attach the Slats (P9) to the assembled frame using 35 x Screws (H5) as shown. Ensure the slats are centred before screwing them to the bed frame.

Step 10

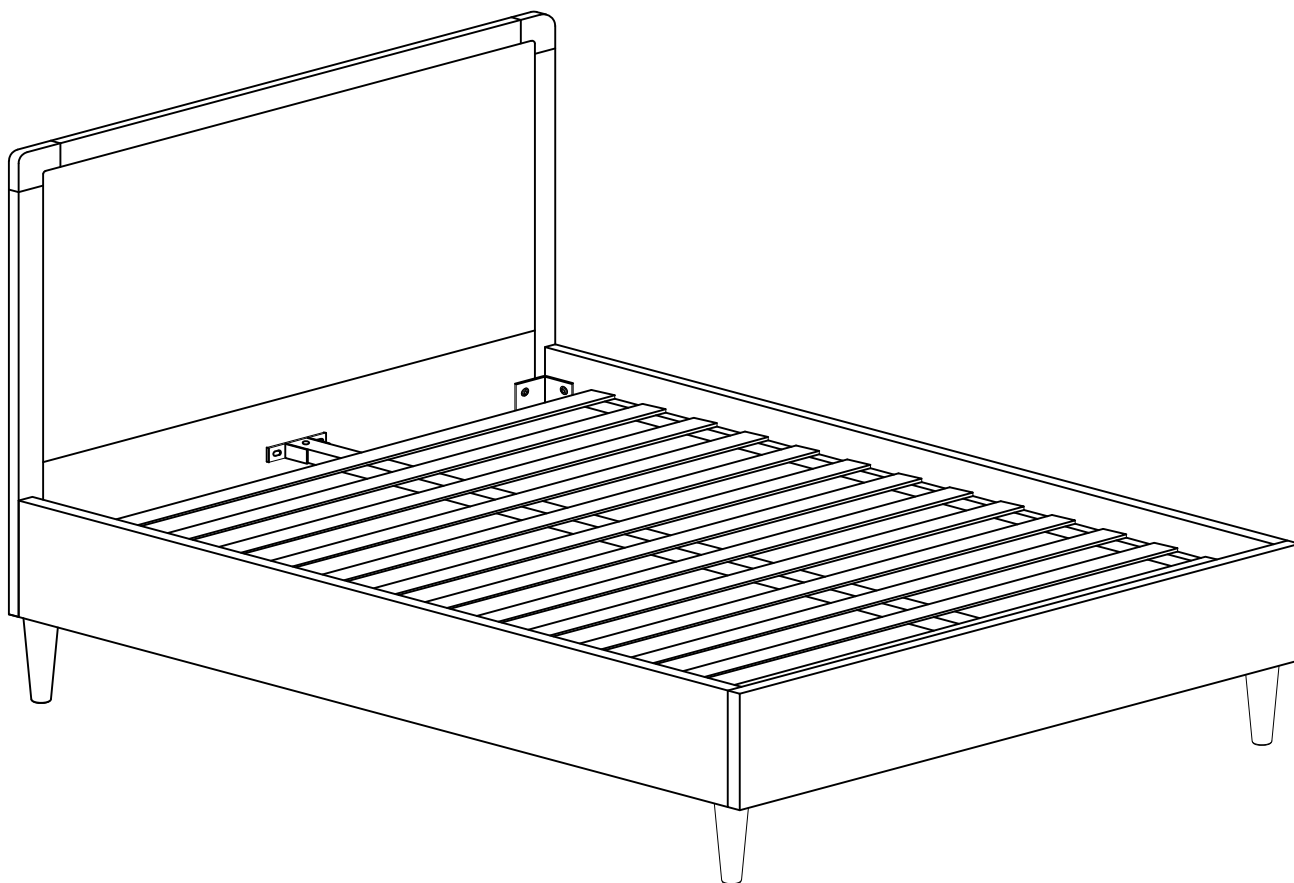

Job Complete

In the interest of our environment please dispose of all packaging thoughtfully.