

OMF

Version 1.0

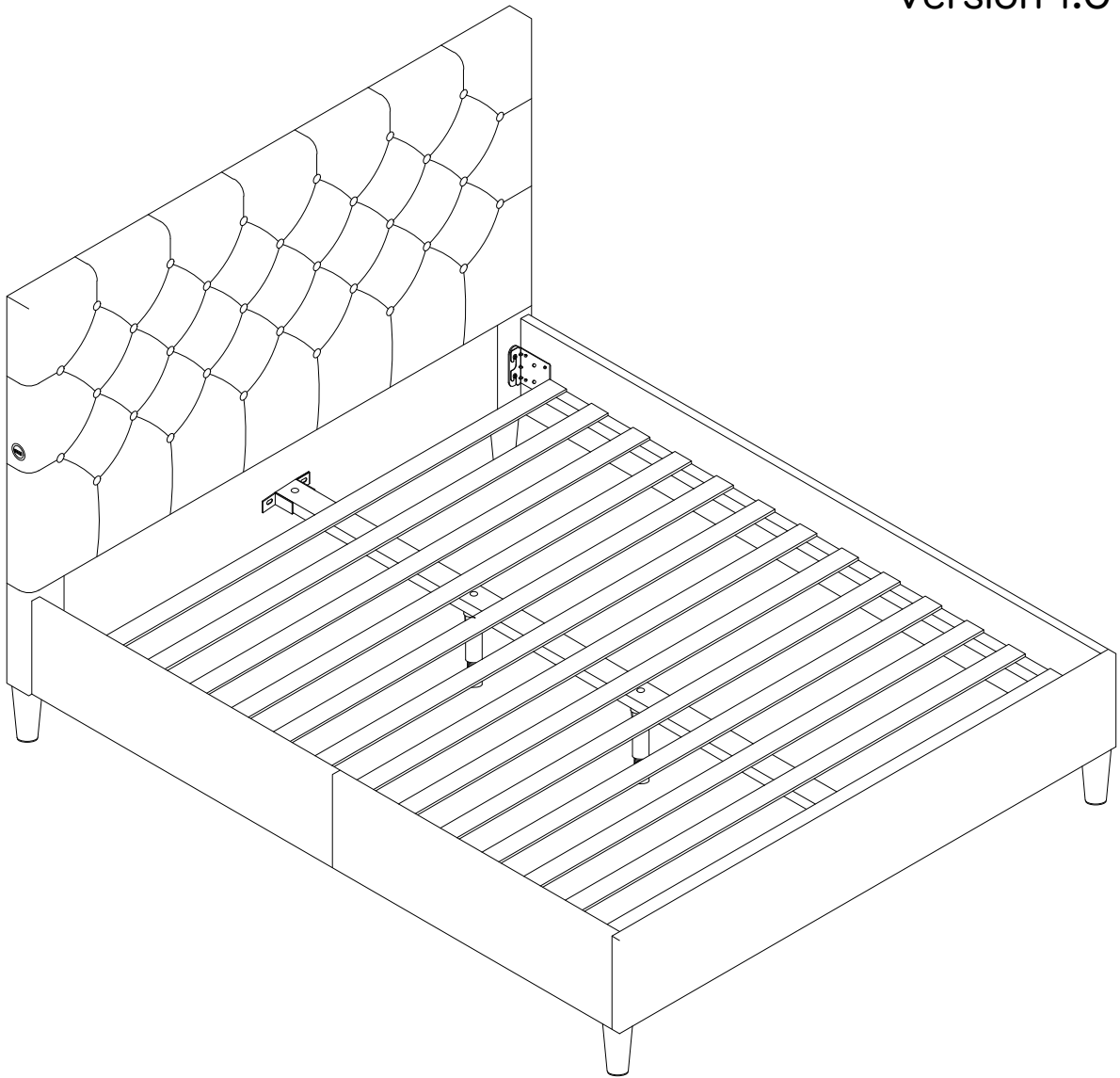

TWO PEOPLE

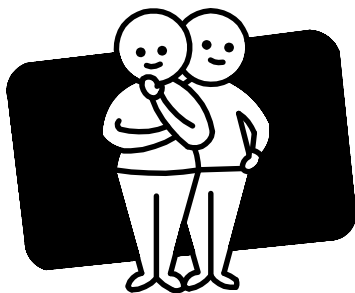

REQUIRED

RUBY

DOUBLE BED

Enjoy
Your purchase From

OMU

Assembly checklist



Read through the instructions carefully before you begin.



Make sure you have all the required tools. Never use power tools unless instructed.

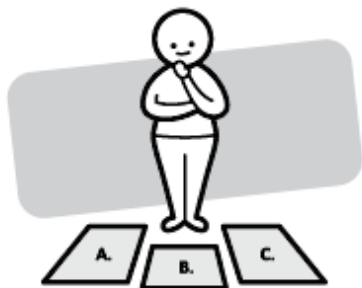

Identify and lay out all of the components before you begin assembly.

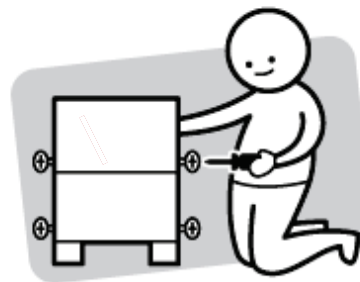

Unless instructed, do not fully tighten screws until the item is fully assembled.

Useful Information



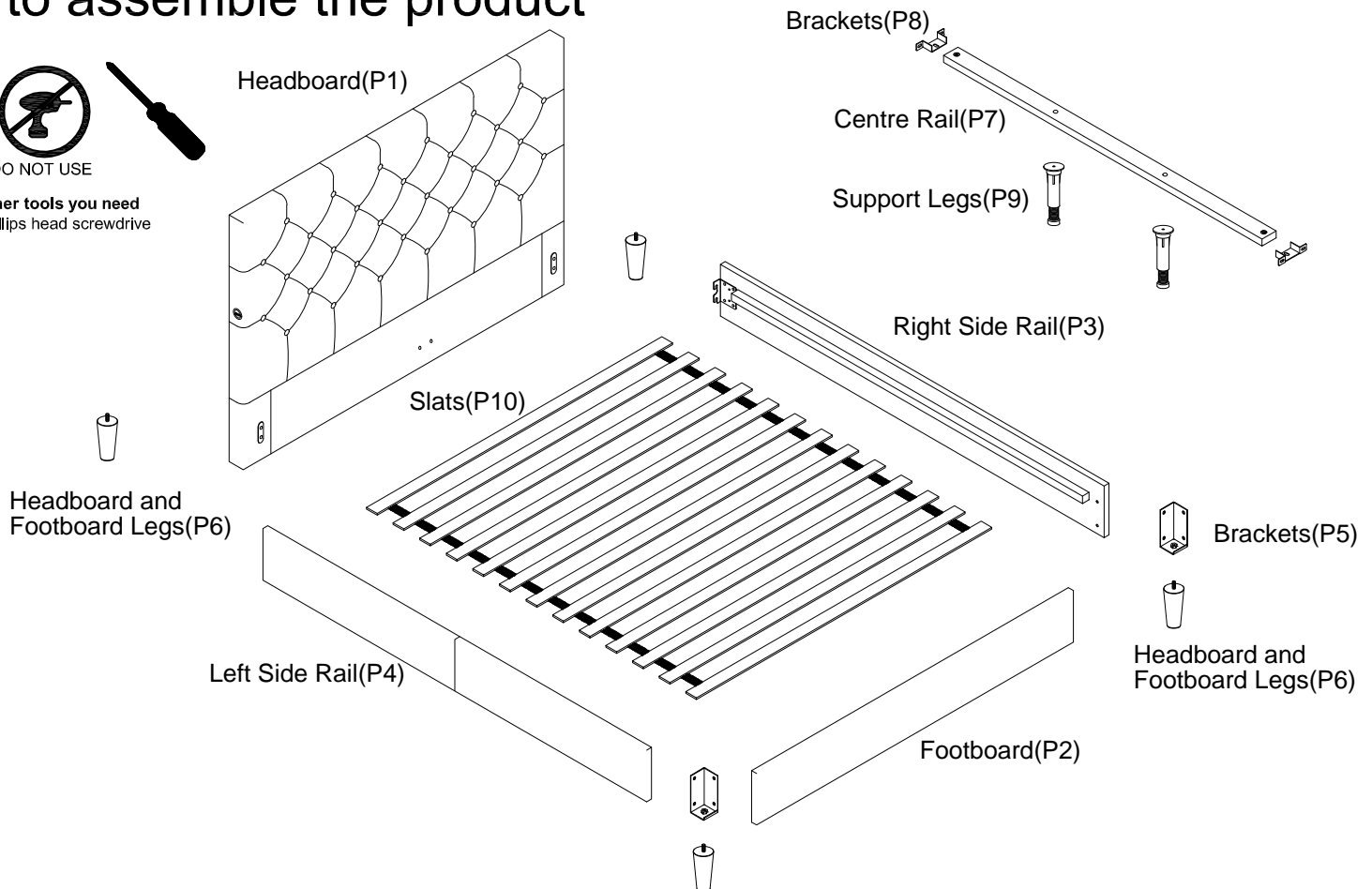

- ! Never use power tools unless specifically instructed. They can damage your components or hardware if used incorrectly.
- ! The most common mistakes made during assembly are using the wrong hardware or getting components back to front.
- ! Always use a soft surface (such as carpet or cardboard) when assembling your product to avoid scratching or damaging the surface of the product.
- ! Bulky items such as wardrobes and bunk beds should be assembled in the room they will be used in as they may not fit through a door once assembled.
- ! Never use any glue until you are certain that the parts belong together.
- ! Periodically check and re-tighten all fasteners. Check the product care label or website for product care instructions.
- ! If you are having any difficulties assembling your product, missing any hardware or components please visit our website Help Centre for further assistance.

What you need to assemble the product

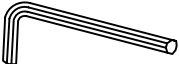

Parts list

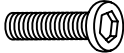
- Box 1 :** Footboard(P2) ; Right Side Rail(P3) ; Left Side Rail(P4) ; Brackets (P5) ;
Headboard/Footboard Legs(P6) ; Centre Rail(P7) ; Brackets(P8) ; Support Legs(P9) ; Hardware Pack
- Box 2 :** Headboard(P1)
- Box 3 :** Slats(P10)

			
(Big Head Bolts) 4 x M8 x 18mm (H1)	(Allen Key) 1 x M5 (H2)	(Small Bolts) 14 x M8 x 20mm (H3)	(Washers) 16 x M8 x 19mm (H4)
			
(Large Bolts) 2 x M8 x 40mm (H5)	(Screws) 39 x M4 x 32mm (H6)		

Please make sure you have all these parts before you start

Step 1

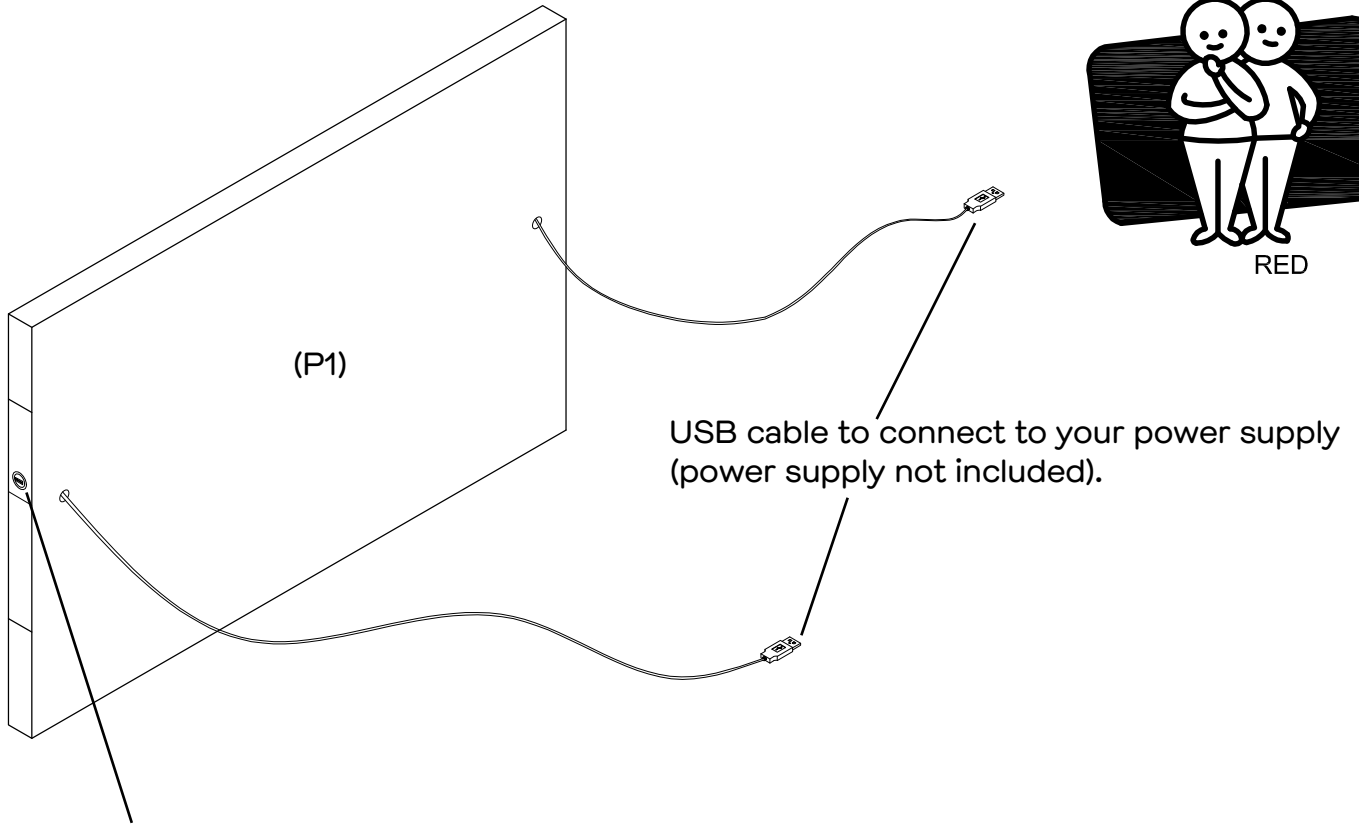
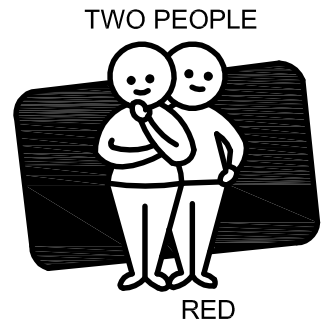

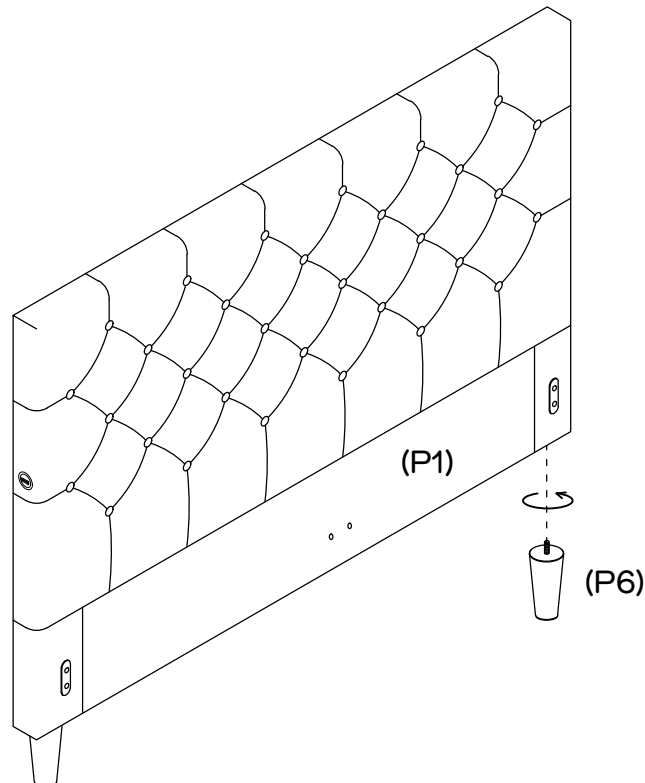

The USB portal can be used to charge your device (USB cable not included).

Step 2



Attach 2 x legs (P6) to the bottom of headboard (P1) , rotate the legs until they are fully tightened.

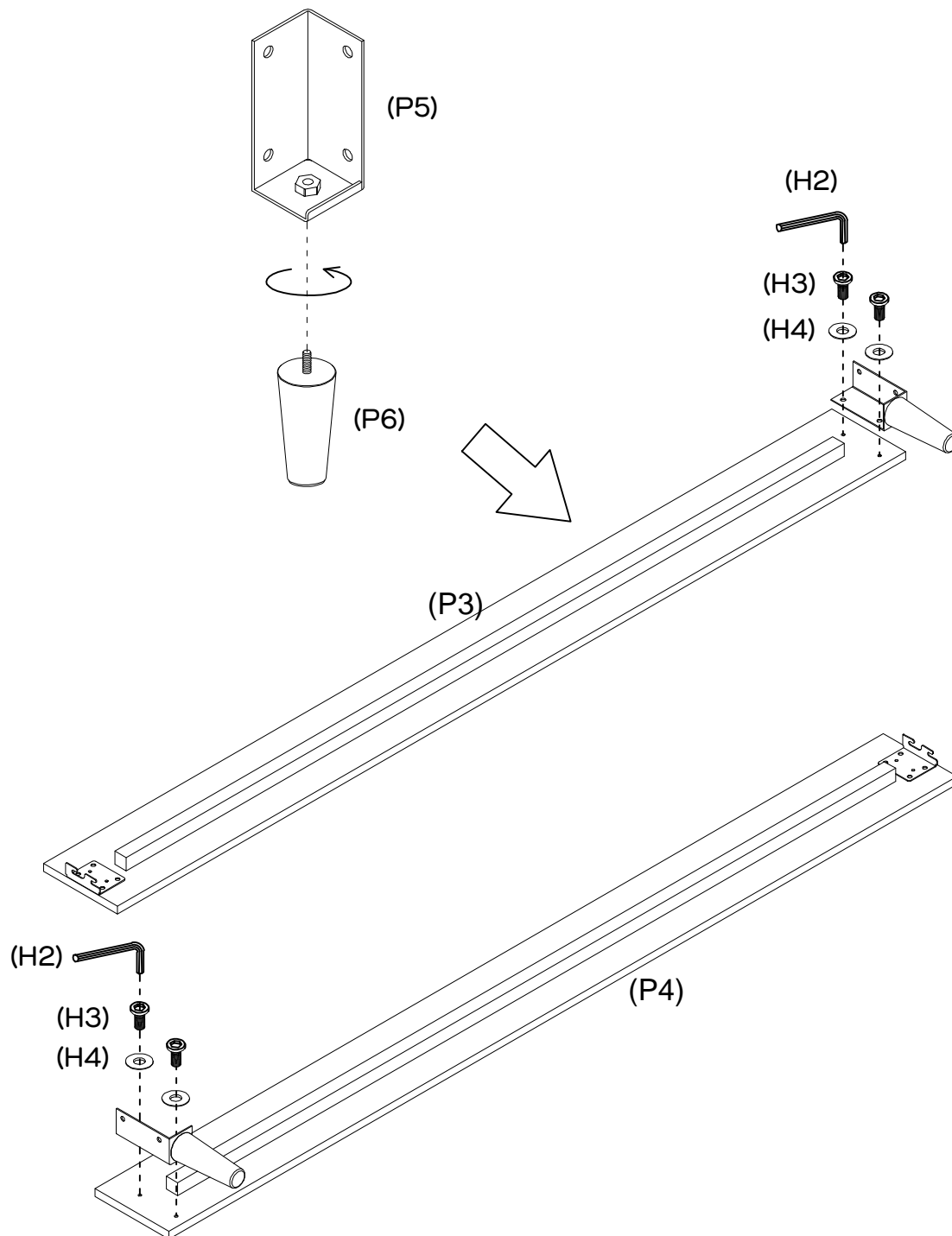

Step 3

You will need		
		
Allen Key (H2)	4 x Small Bolts 20mm (H3)	4 x Washers M8 (H4)



Attach footboard legs(P6) to the bottom of leg brackets(P5), rotate the legs until they are fully tightened. Then, attach leg brackets(P5) to the side rails(P3/P4) with 4 x washers (H4) and 4 x bolts (H3) by using the allen key (H2). Please do not tighten all the bolts until step 8 .

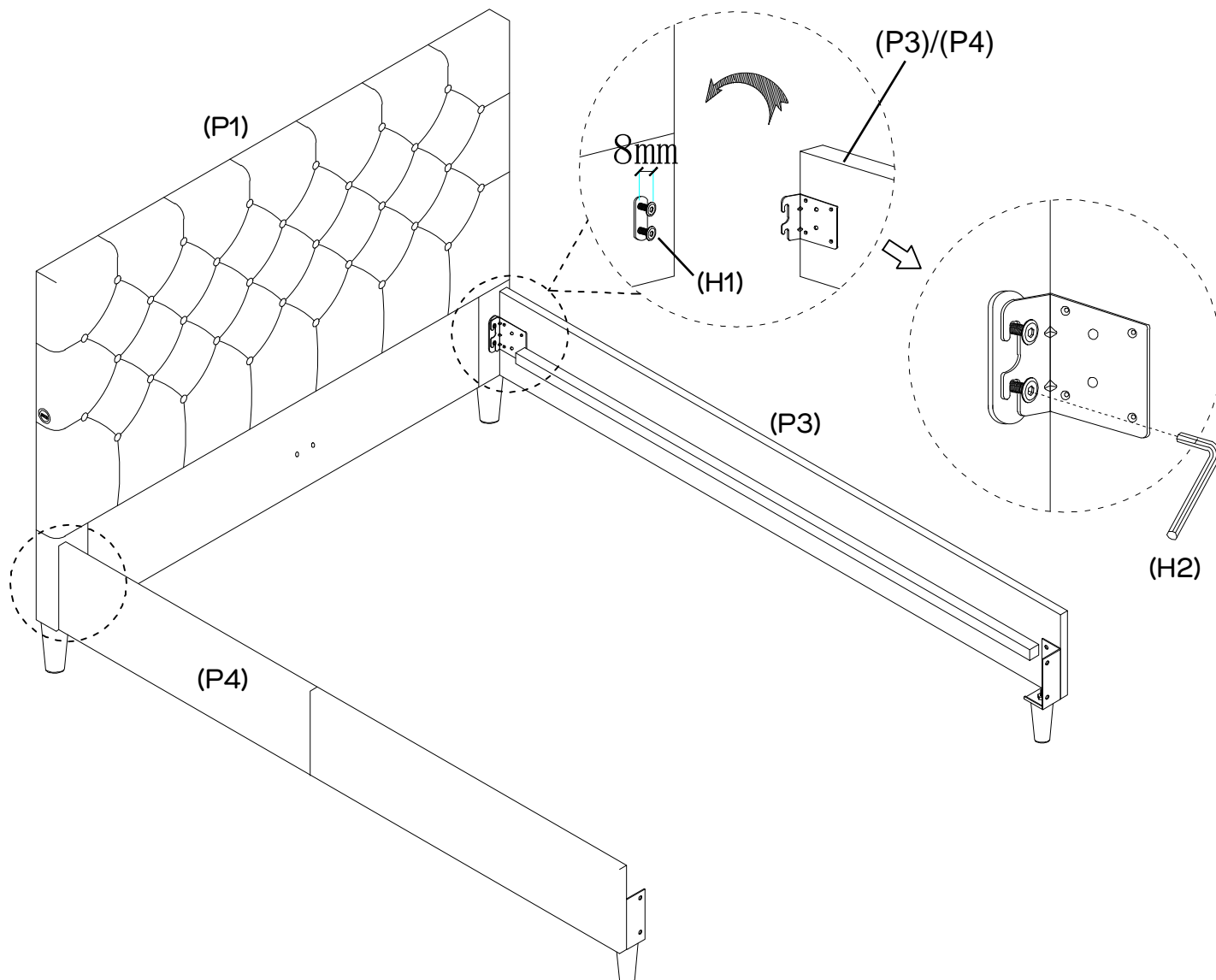

Step 4

You will need	
	
4 x Bolts 18mm (H1)	Allen Key (H2)



Install 4 x bolts (H1) to the brackets of the headboard (P1) by using allen key (H2) as shown, do not tighten the bolts and keep them 8mm loose.
Then attach side rails (P3)/(P4) to headboard (P1) by slotting the bracket onto the bolts as shown. Please do not tighten bolts until step 8.

Step 5



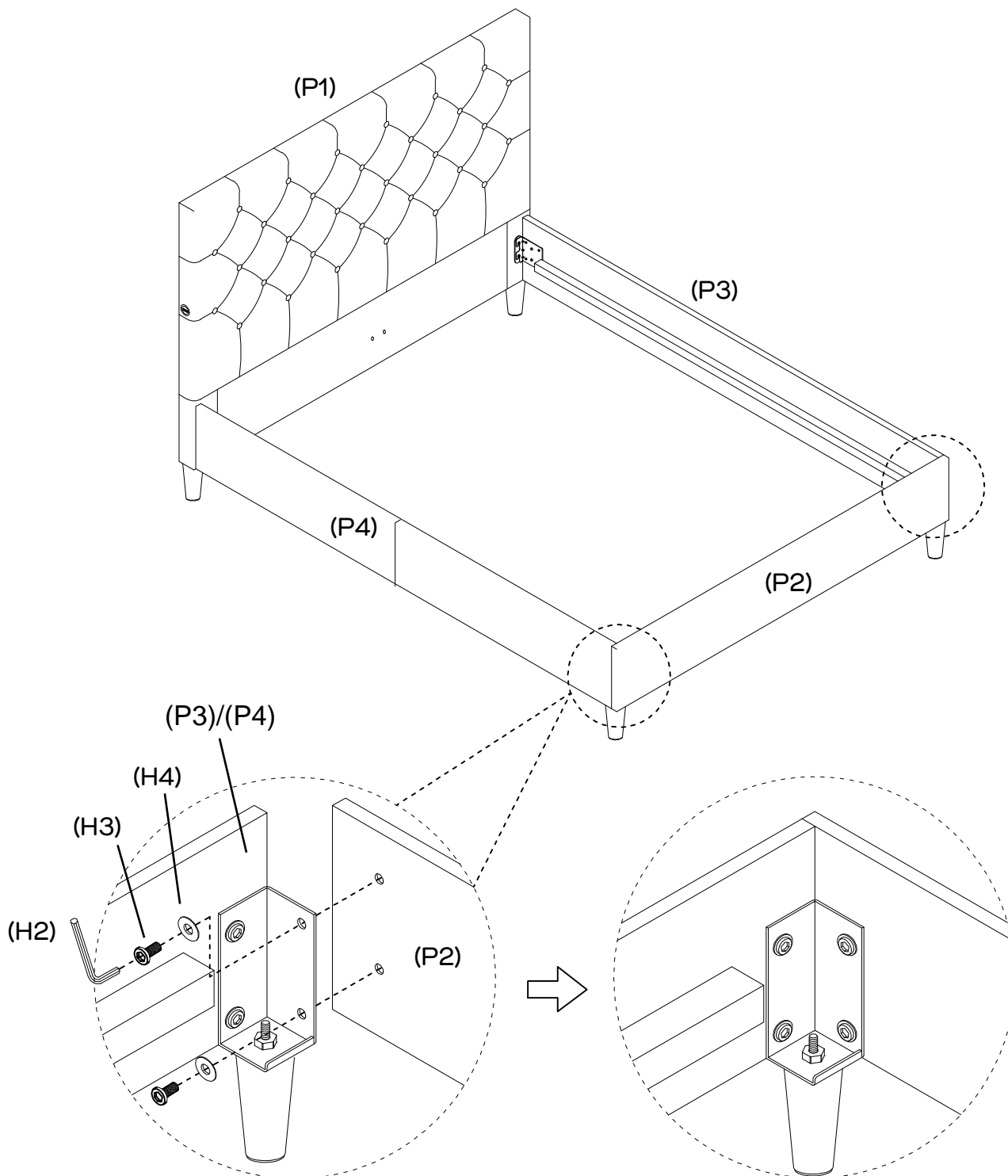

You will need		
		
Allen Key (H2)	4 x Small Bolts 20mm (H3)	4 x Washers M8 (H4)



Attach the footboard (P2) to the side rails (P3/P4) with 4 x small bolts (H3) and 4 x washers (H4) by using allen key (H2).

Please do not tighten bolts until step 8.

Step 6

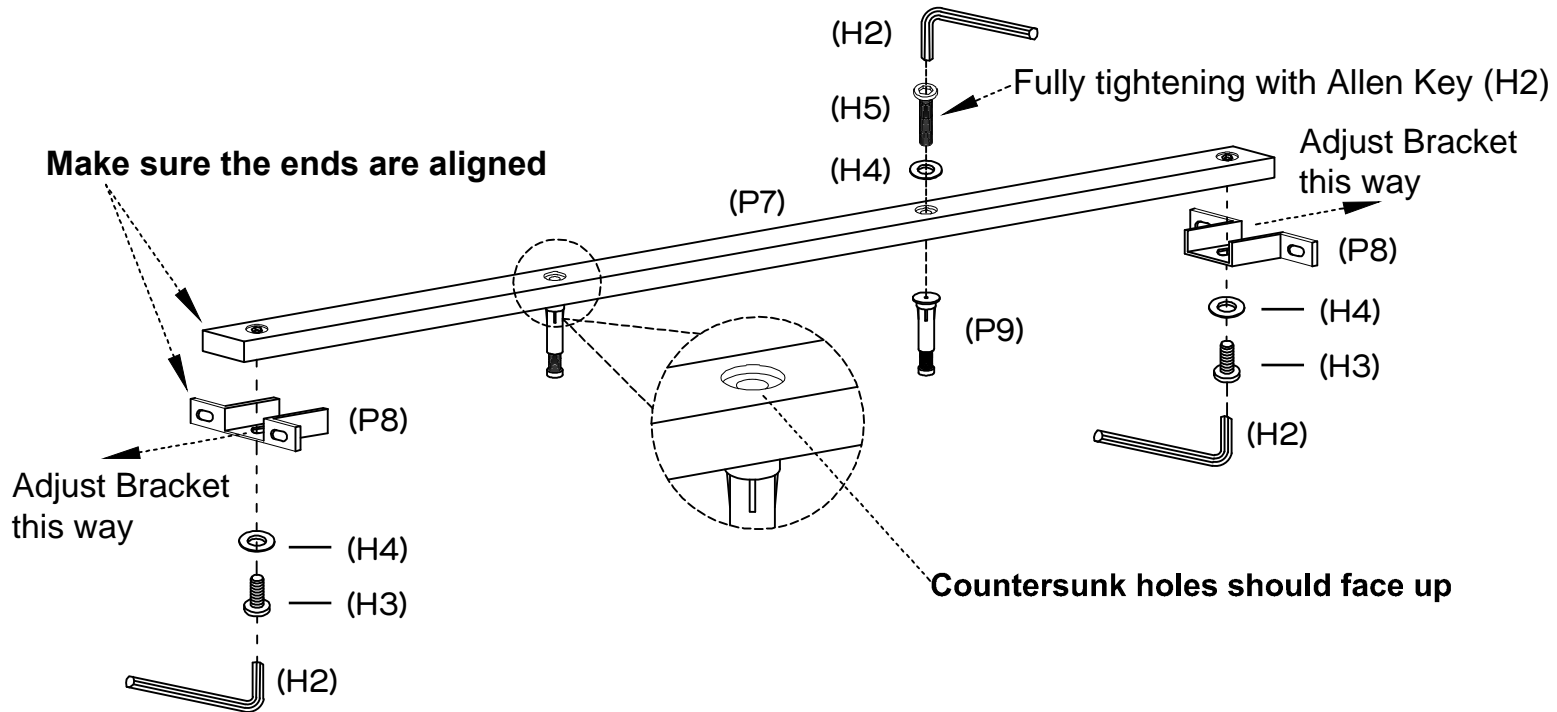

You will need			
			
Allen Key (H2)	2 x Small Bolts 20mm (H3)	4 x Washers M8 (H4)	2 x Large Bolts 40mm (H5)



Attach the support legs (P9) to the centre rail (P7) with 2 x large bolts (H5) and 2 x washers (H4) by using allen key (H2).

Attach 2 x bracket (P8) to the centre rail (P7) with 2 x small bolts (H3) and 2 x washers (H4) by using allen key (H2) as shown.

Step 7

You will need		
		
Allen Key (H2)	4 x Small Bolts 20mm (H3)	4 x Washers M8 (H4)

You must use.

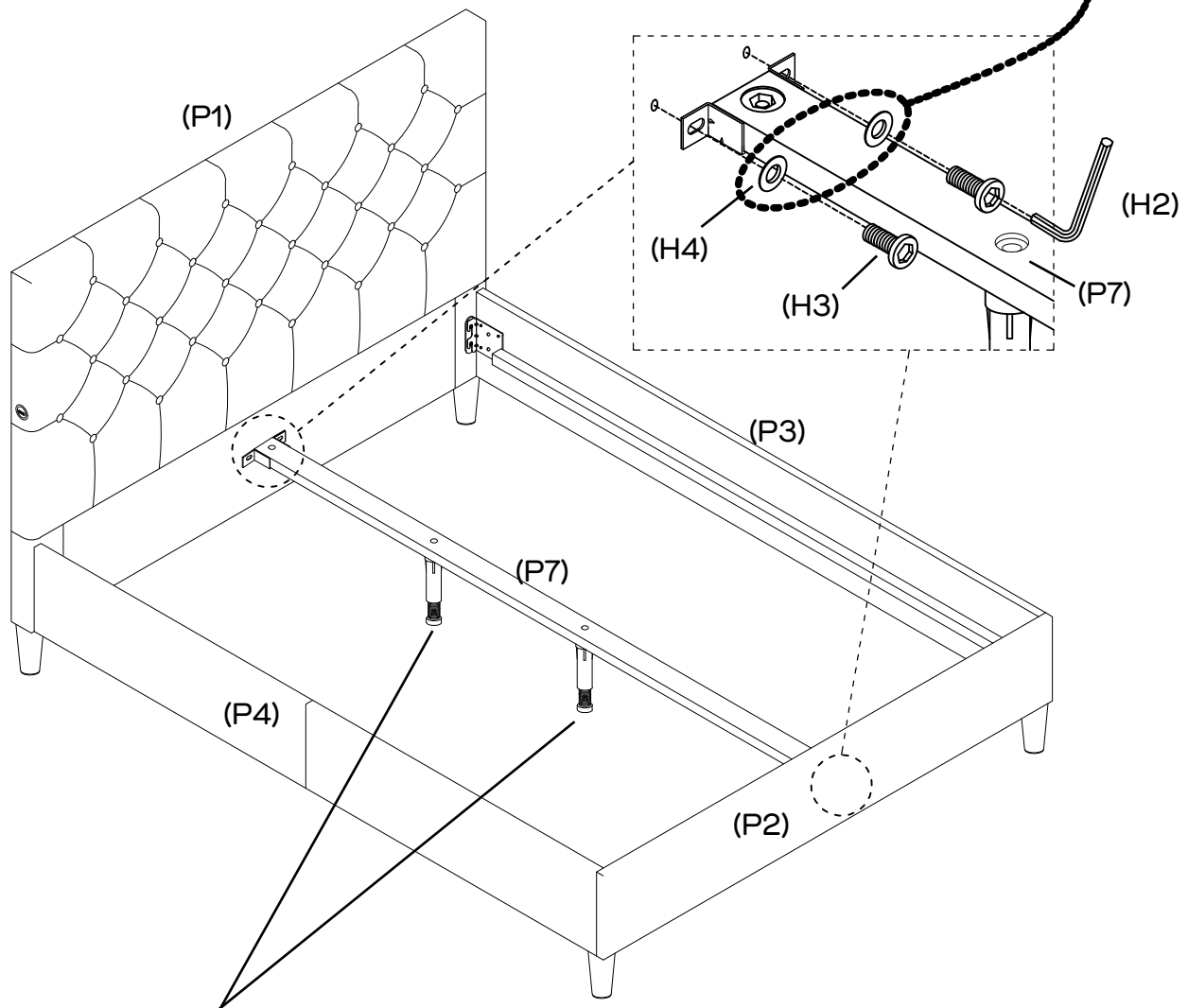

Twist the support legs(P9) to be attached to flooring

Slot the centre rail (P7) into the headboard (P1) and footboard (P2).

Rotate 4 x small bolts (H3), and 4 x washers (H4) by using allen key (H2) to the headboard (P1) and footboard (P2). Fully tighten all the small bolts (H3).

Step 8

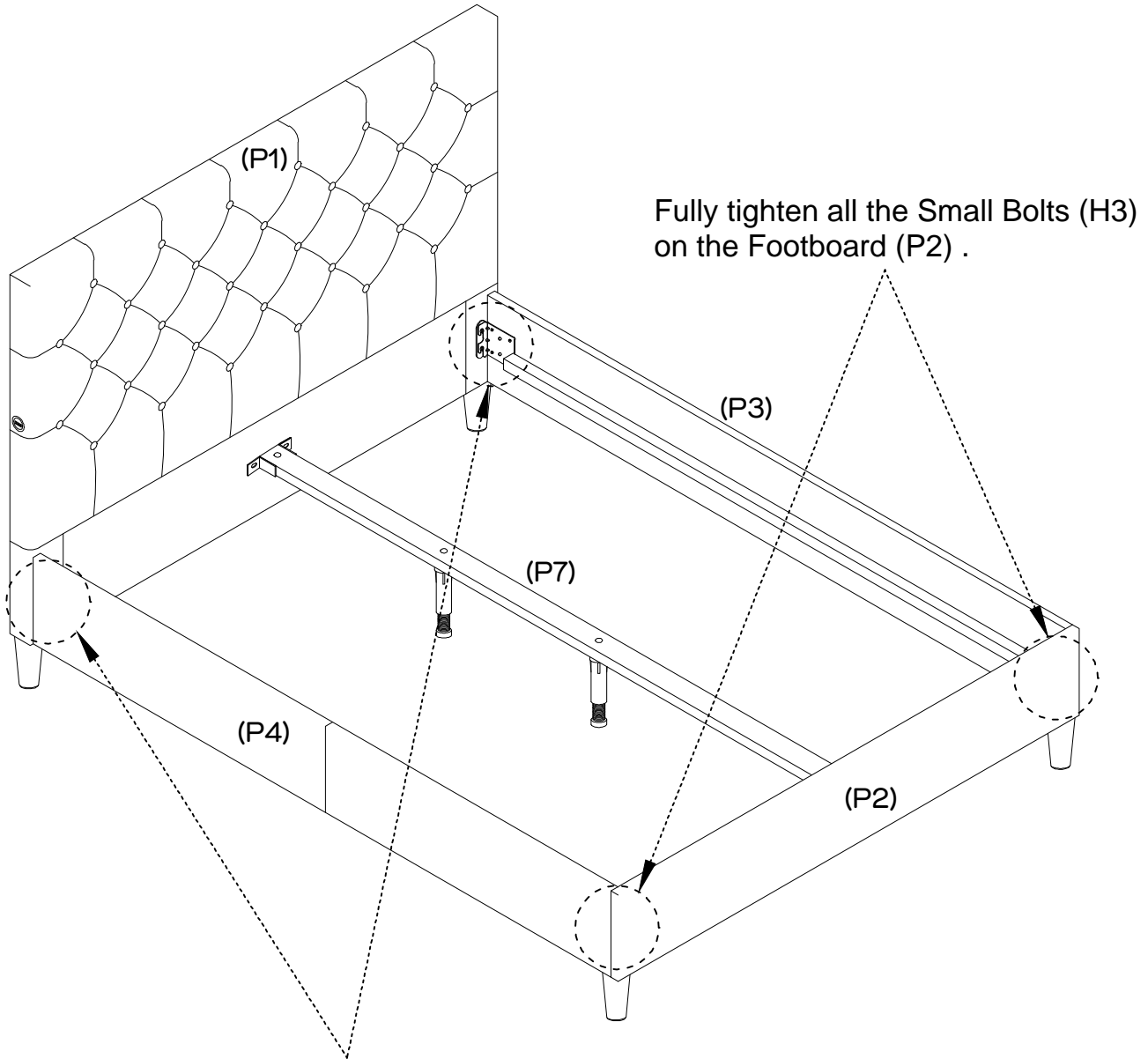

Fully tighten all the Big Head Bolts (H1) on the Headboard (P1) .

Step 9

You will need



Allen Key
(H2)



39 x Screws
(H6)



Phillips head screwdriver
(not provided)

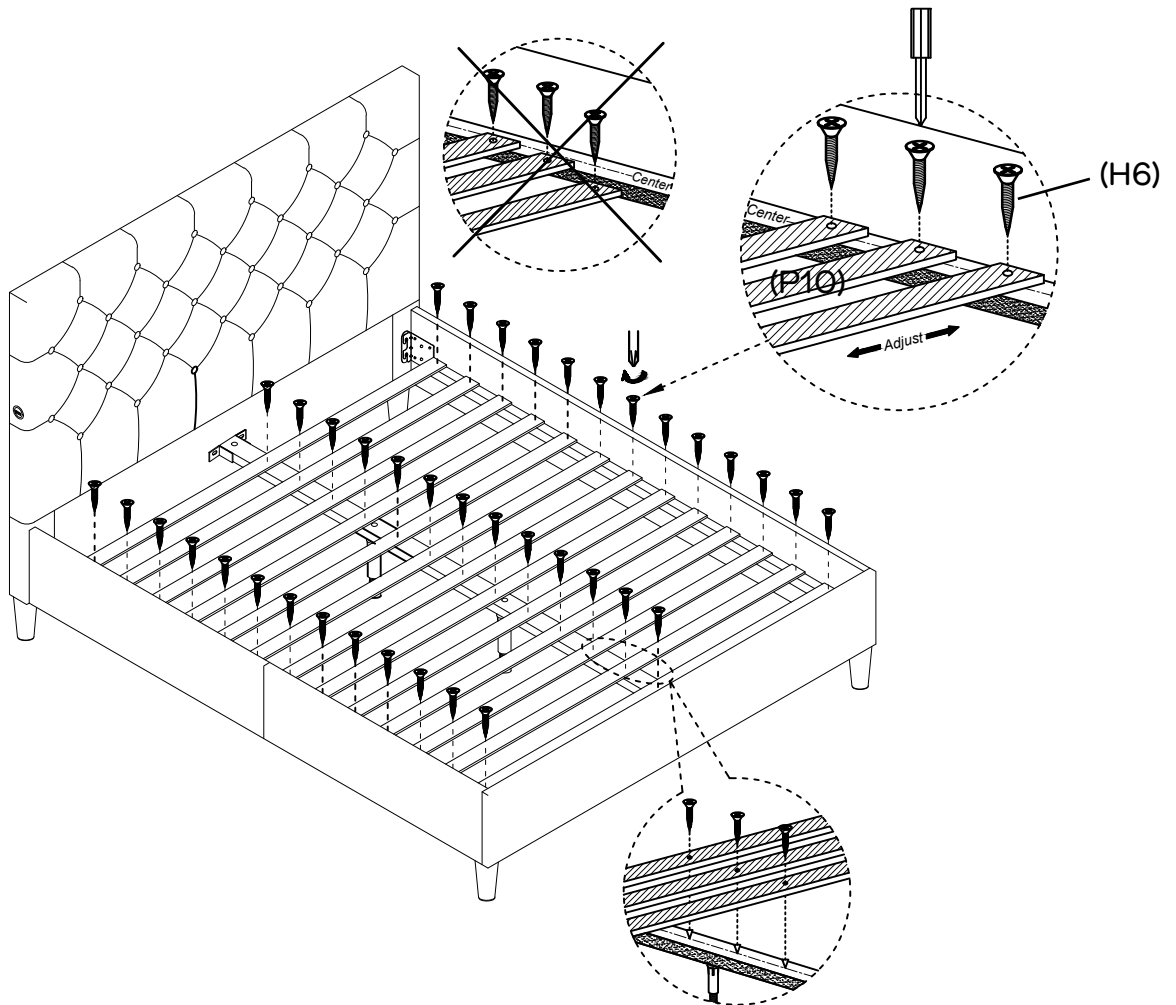
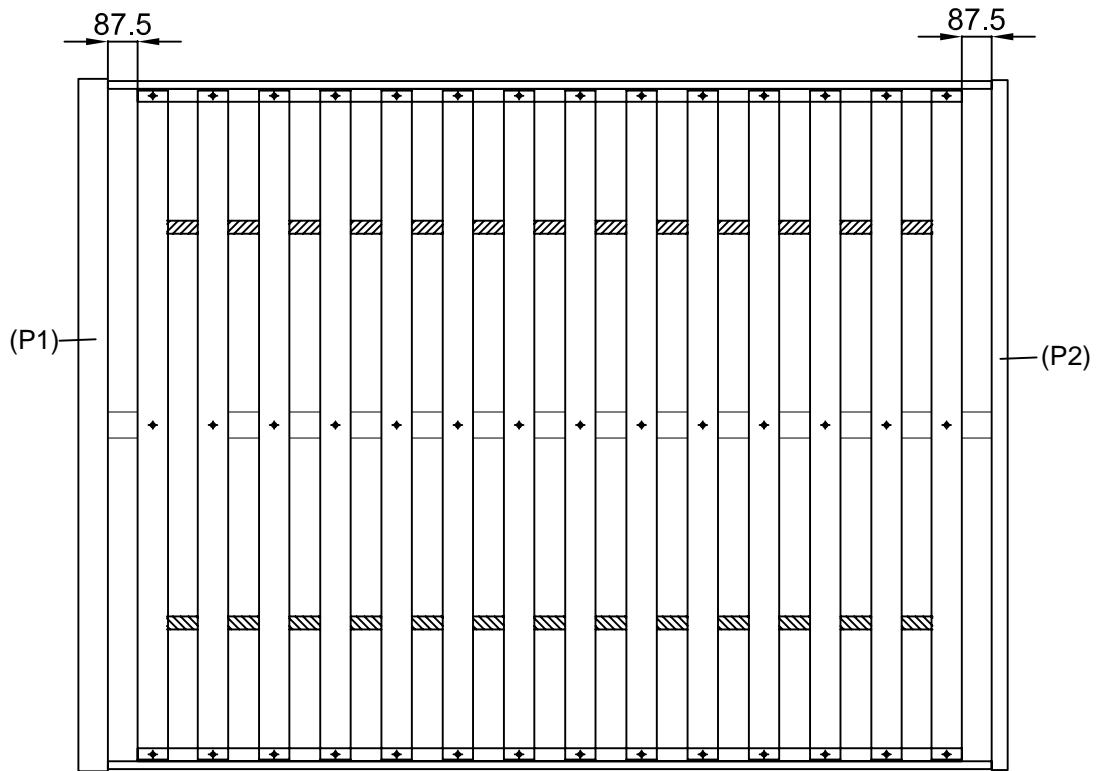

Make sure the inner space is square.

Then assemble all the slats (P10) down by using 39 x screws (H6).

Adjust the slats to the center before screwing them onto the bed frame.

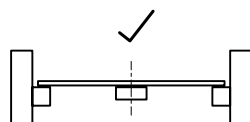
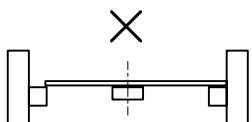

Step 10

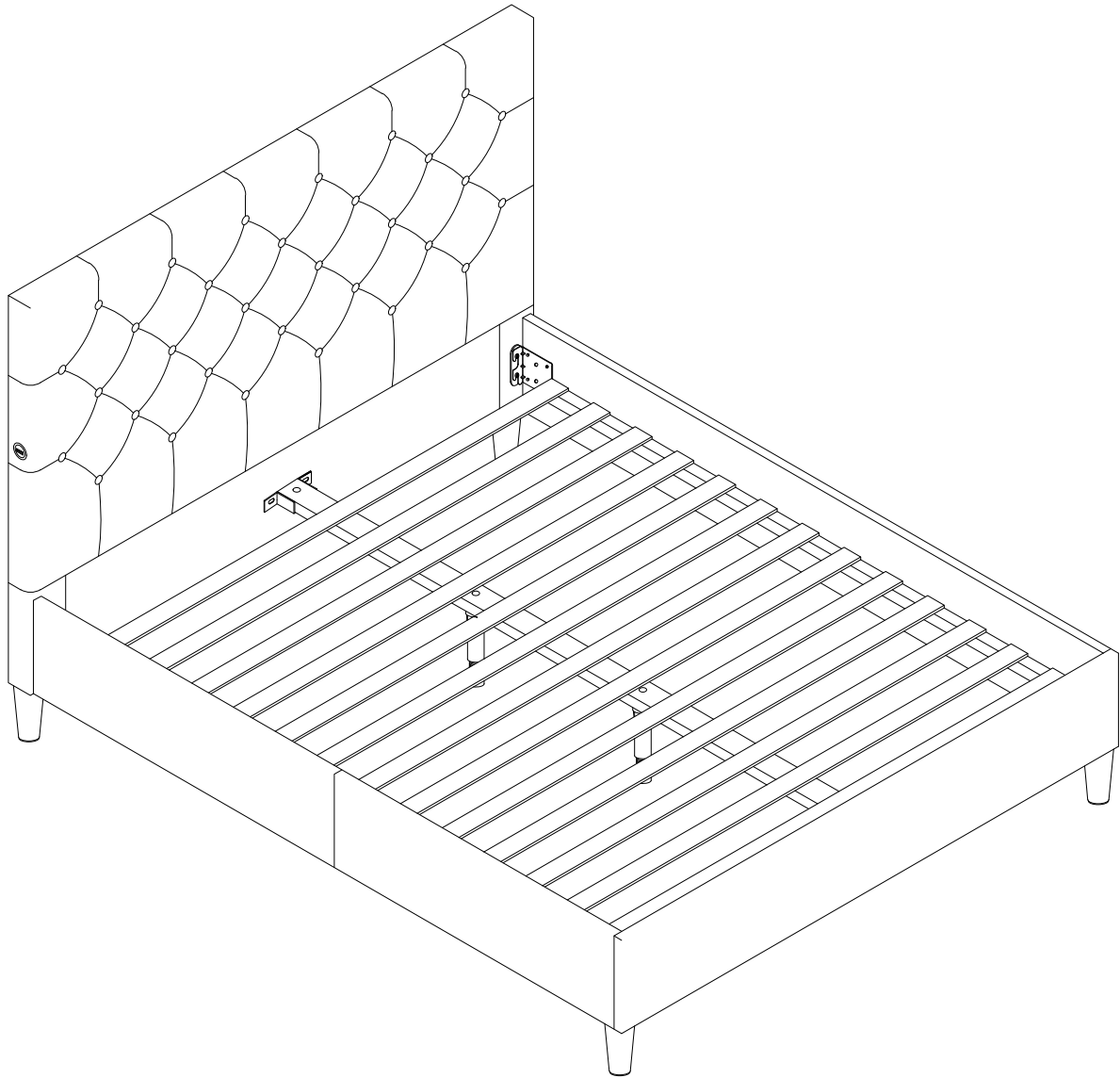

Job Complete

In the interest of our environment please dispose of all packaging thoughtfully.