

OMF

Version 1.0

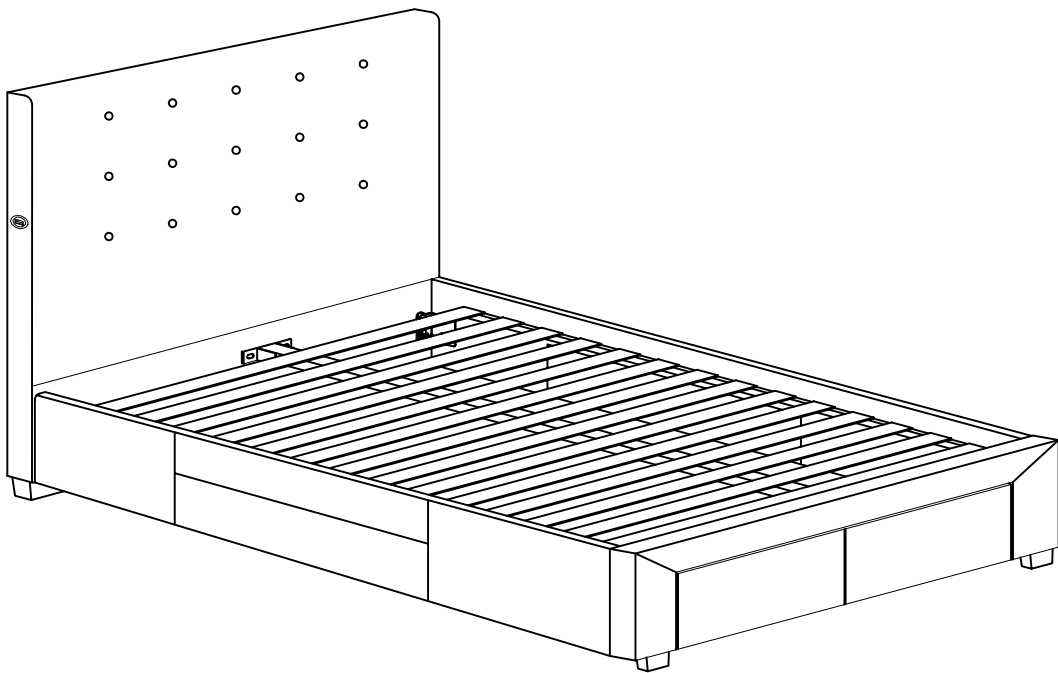

TWO PEOPLE

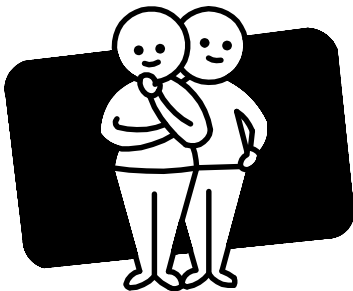

REQUIRED

TORQUAY

QUEEN BED

Enjoy
Your purchase From

OML

Assembly checklist



Read through the instructions carefully before you begin.



Make sure you have all the required tools. Never use power tools unless instructed.

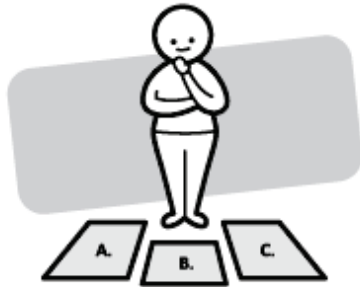

Identify and lay out all of the components before you begin assembly.

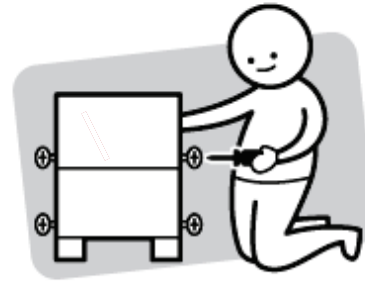

Unless instructed, do not fully tighten screws until the item is fully assembled.

Useful Information

- ! Never use power tools unless specifically instructed. They can damage your components or hardware if used incorrectly.
- ! The most common mistakes made during assembly are using the wrong hardware or getting components back to front.
- ! Always use a soft surface (such as carpet or cardboard) when assembling your product to avoid scratching or damaging the surface of the product.
- ! Bulky items such as wardrobes and bunk beds should be assembled in the room they will be used in as they may not fit through a door once assembled.
- ! Never use any glue until you are certain that the parts belong together.
- ! Periodically check and re-tighten all fasteners. Check the product care label or website for product care instructions.
- ! If you are having any difficulties assembling your product, missing any hardware or components please visit our website Help Centre for further assistance.

What you need to assemble the product



DO NOT USE

Other tools you need
Phillips head screwdriver

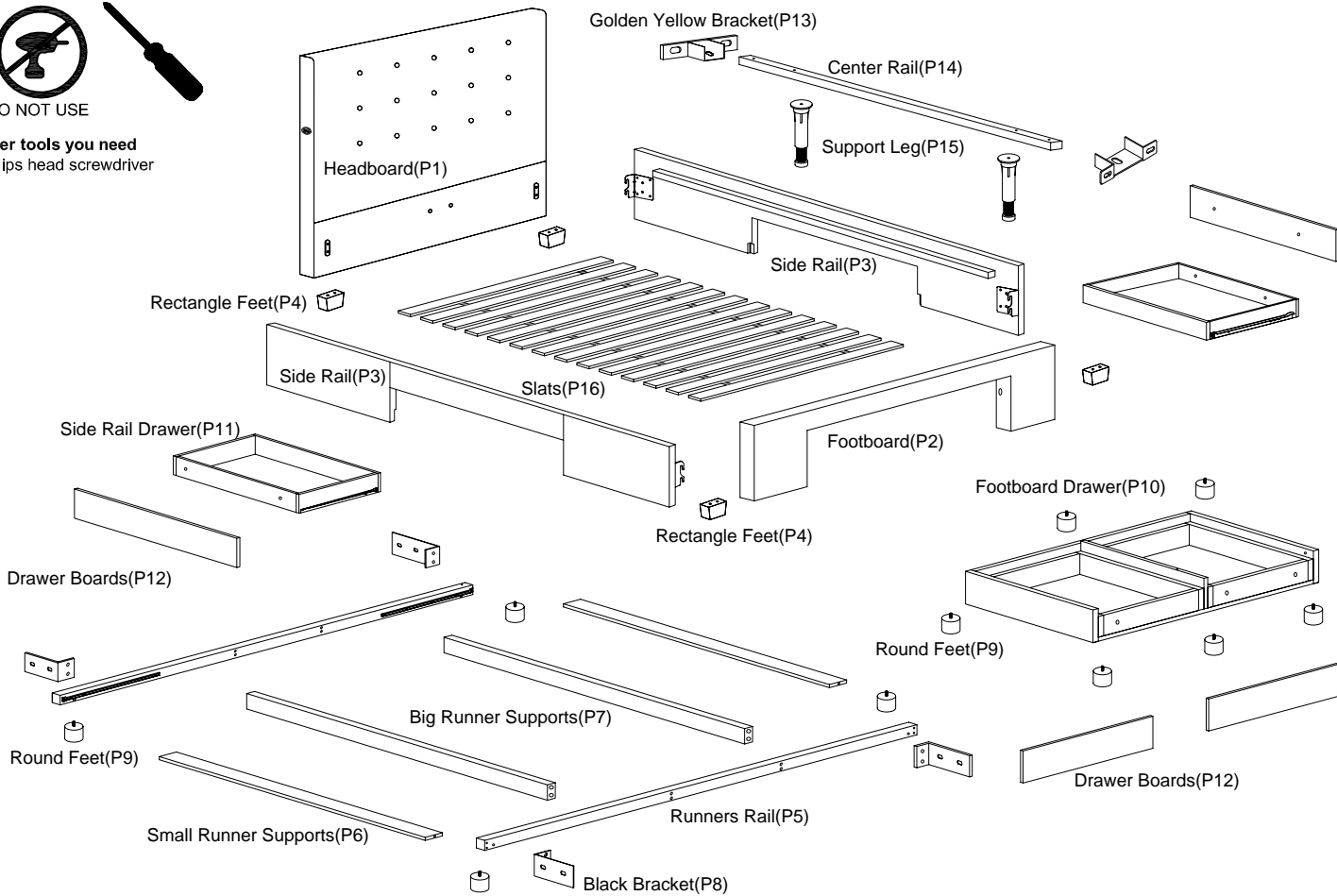

Parts list

Box 1 : Footboard(P2) ; Side Rails(P3) ; Rectangle Feet(P4) ; Runners Rail(P5) ; Small Runner Supports(P6) ; Big Runner Supports(P7) ; Black Brackets(P8) ; Round Feet(P9) ; Drawer Boards(P12) ; Golden Yellow Bracket(P13) ; Center Rail(P14) ; Support Legs(P15) ; Hardware Pack

Box 2 : Headboard(P1)

Box 3 : Footboard Drawer(P10) ; Side Rail Drawers(P11)

Box 4 : Slats(P16)

(Large Screws) 8 x M4 x 50mm (H1)	(Big Head Bolts) 8 x M8 x 18mm (H2)	(Allen key) 1 x M5 (H3)	(Medium Bolts) 22 x M8 x 20mm (H4)	(Washers) 34 x M8 x 19mm (H5)	(Small Bolts) 12 x M6 x 45mm (H6)
(Super Large Bolts) 4 x M8 x 40mm (H7)	(Large Bolts) 8 x M8 x 30mm (H8)	(Small Screws) 42 x M4 x 38mm (H9)			

Please make sure you have all these parts before you start

Step 1

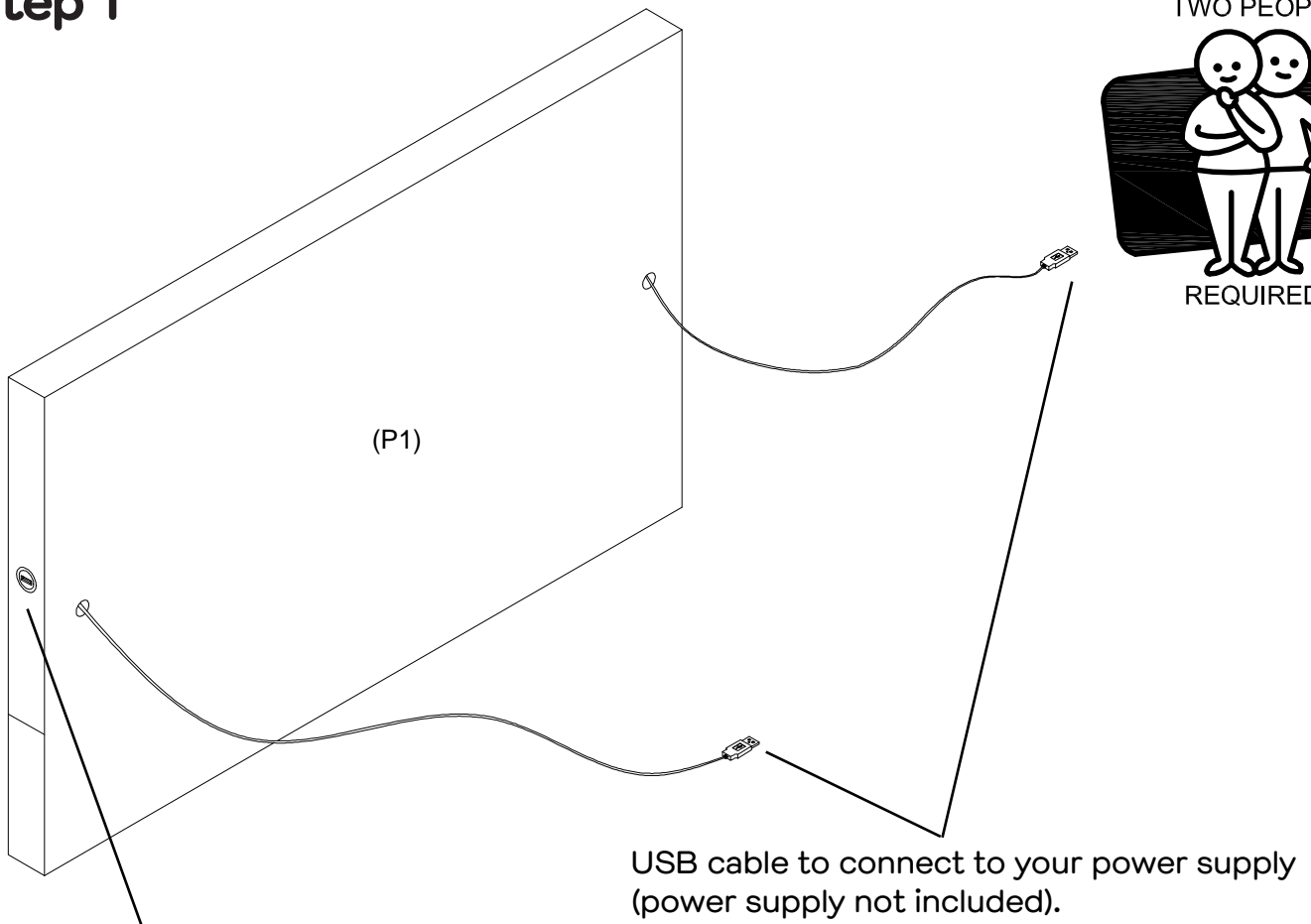
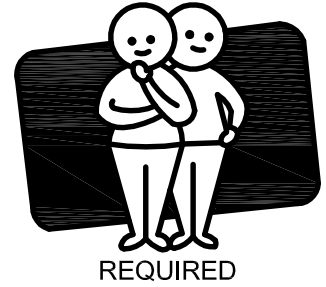

TWO PEOPLE



The USB portal can be used to charge your device (USB cable not included).

Step 2

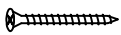
You will need

	
8 x Large Screws 50mm (H1)	Phillips head screwdriver (not provided)

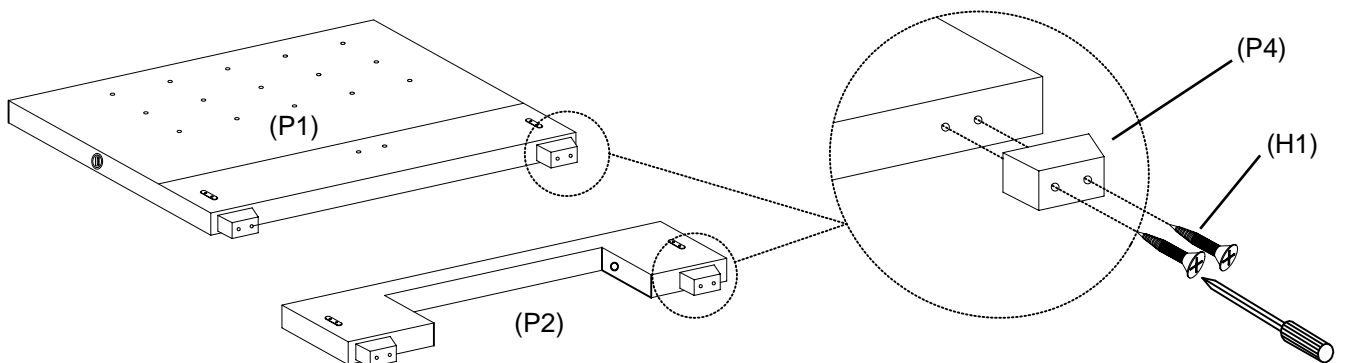

Attach Rectangle Feet(P4) to the bottom of Headboard(P1) and Footboard(P2) with 8 x Large Screws M4 x 50mm(H1).

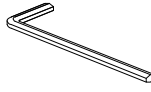

Step 3

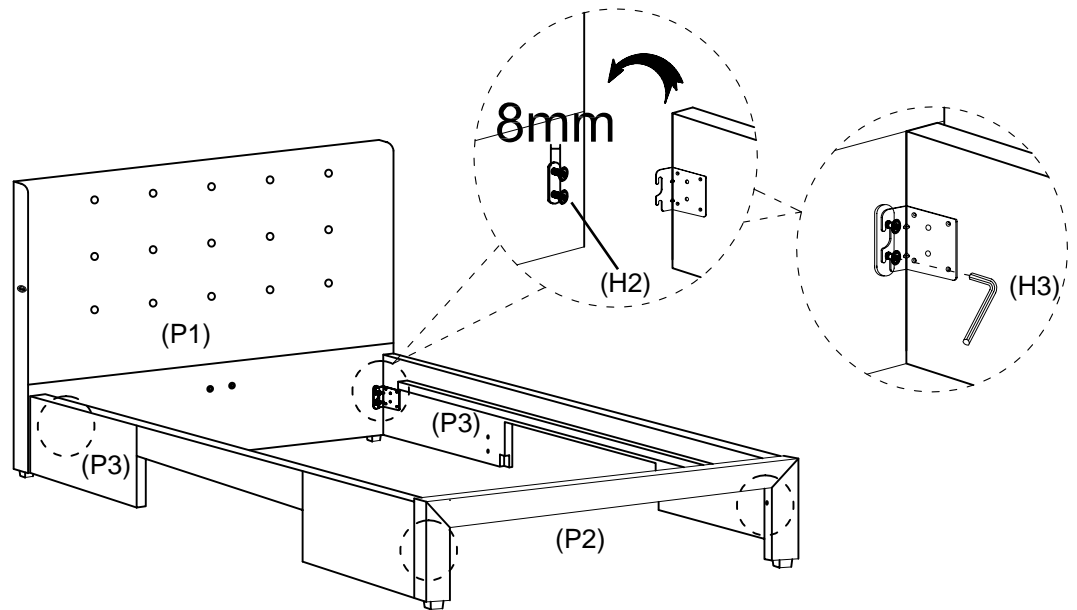
You will need	
	
8 x Bolts 18mm (H2)	Allen Key (H3)



Install the Bolts(H2) to the brackets by using Allen key(H3) as shown, do not tighten the bolts and keep them 8 mm loose. Then attach Side Rail(P3) to Headboard(P1) and Footboard(P2) by slotting the bracket on the Side Rail(P3) over the bolt as shown. Do not fully tighten bolts until step 6.

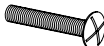

Step 4

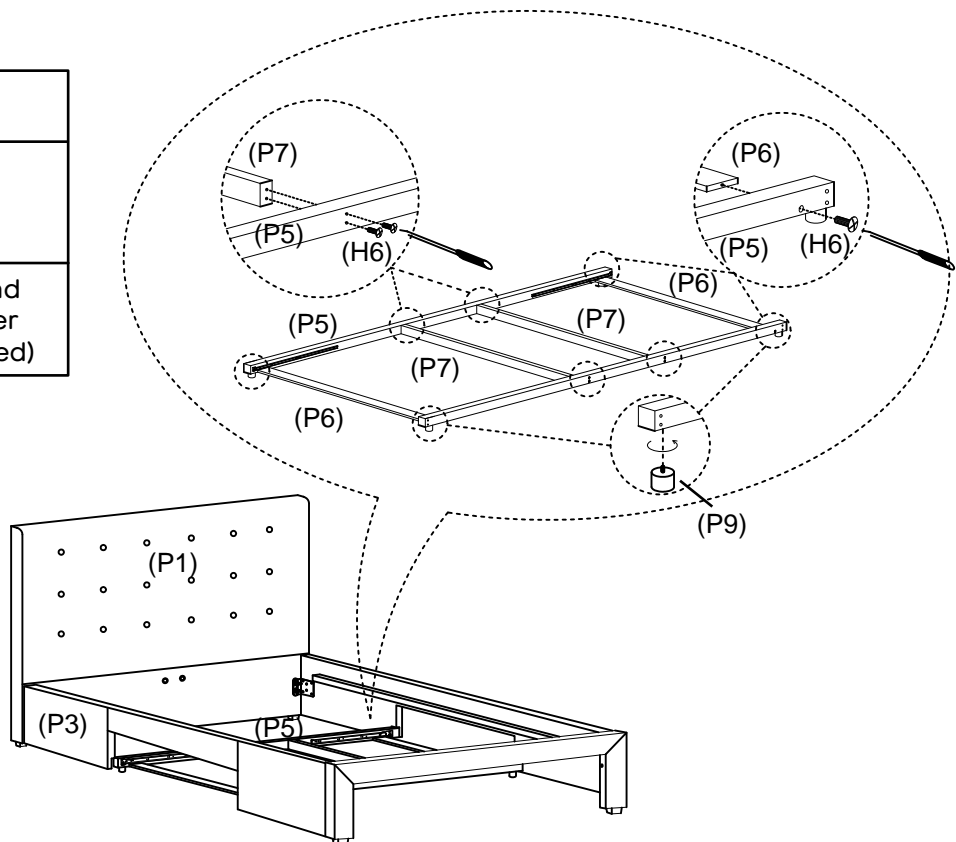
You will need	
	
12 x Bolts 45mm (H6)	Phillips head screwdriver (not provided)



Install 4 x Round Feet(P9) on the bottom of Runners Rail(P5). Then put the Runners Rail(P5) into the inner space as shown. At last, install Small Runner Supports(P6) and Big Runner Supports(P7) to the Runners Rail(P5) with 12 x Bolts(H6).

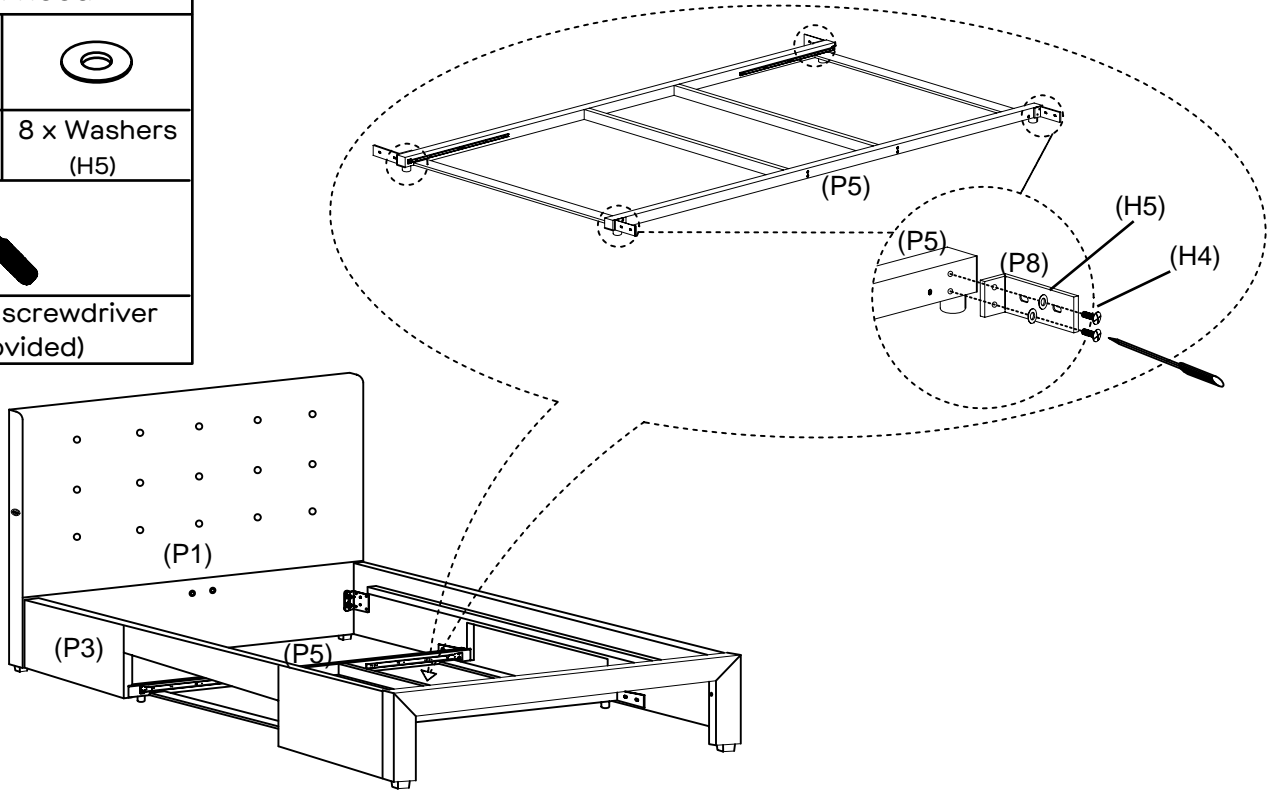

Step 5

You will need	
	
8 x Bolts 20mm (H4)	8 x Washers (H5)
	
Phillips head screwdriver (not provided)	



Attach Black Brackets(P8) to the Runners Rail(P5) with 8 x Bolts 20mm(H4) and 8 x Washers(H5). Do not fully tighten until Step 6.

Step 6

You will need	
	
8 x Bolts 20mm (H4)	8 x Washers (H5)
	
Phillips head screwdriver (not provided)	

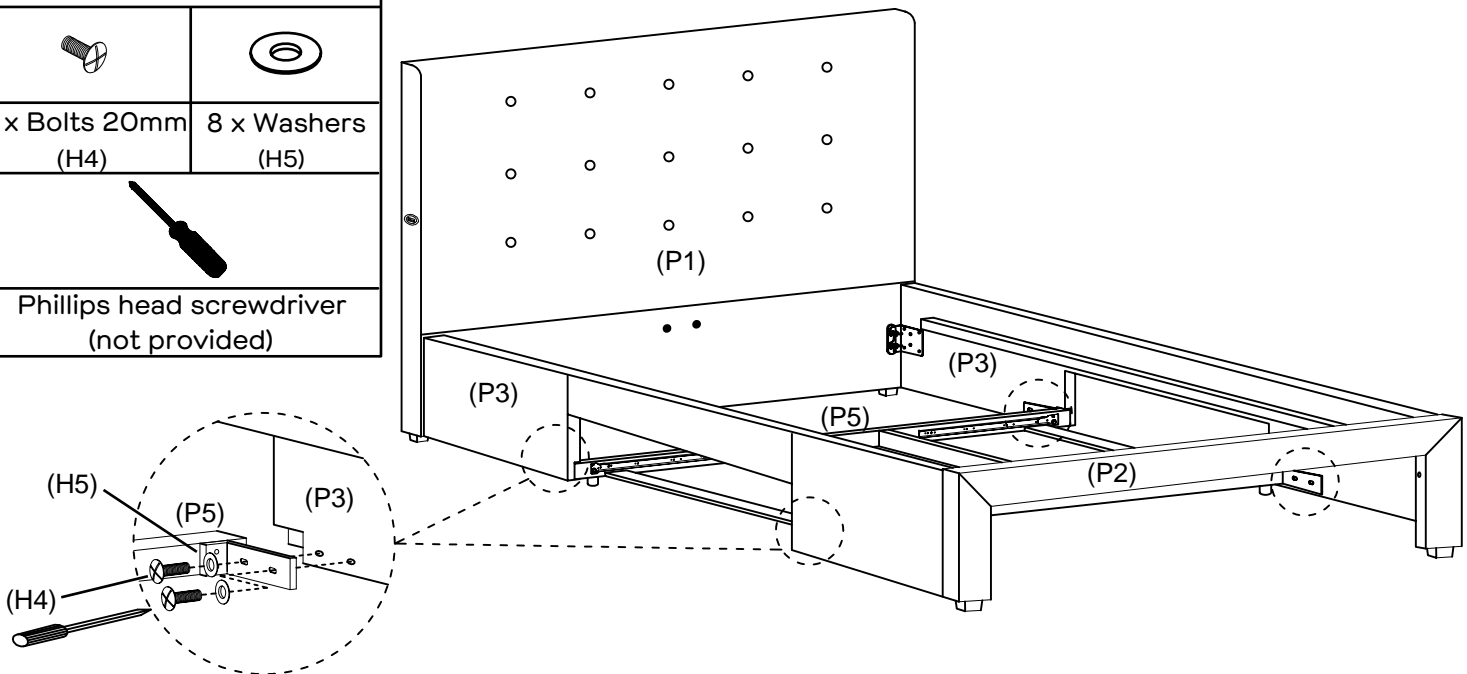

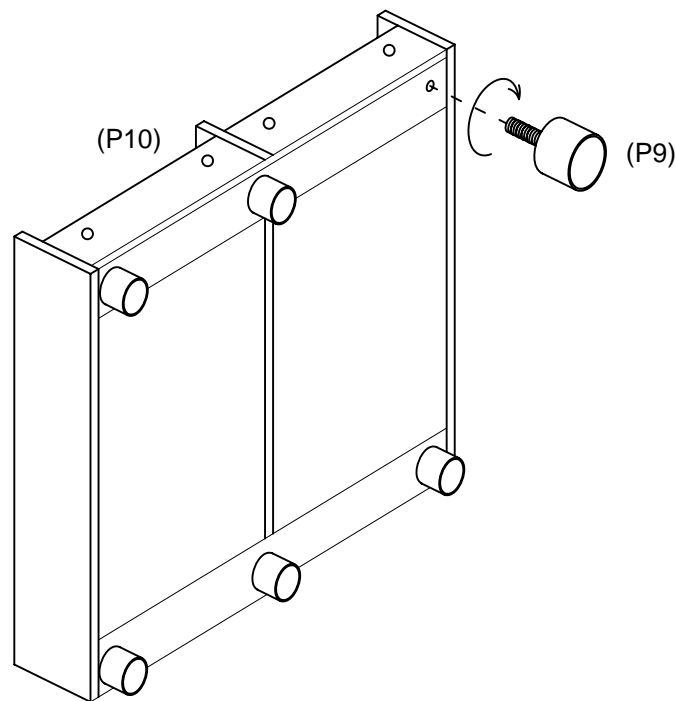

Attach the Runners Rail(P5) to the Side Rails(P3) with 8 x Bolts(H4) and 8 x Washers(H5) by using Phillips head screwdriver. Fully tighten all the bolts(H2) on the Headboard(P1) and Footboard(P2). Please also fully tighten all the bolts(H4) on the black brackets(P8).

Step 7

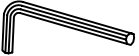

Install 6 x Round Feet(P9) on the bottom of Footboard Drawer(P10) as shown, please make sure you tighten all of them.

Step 8



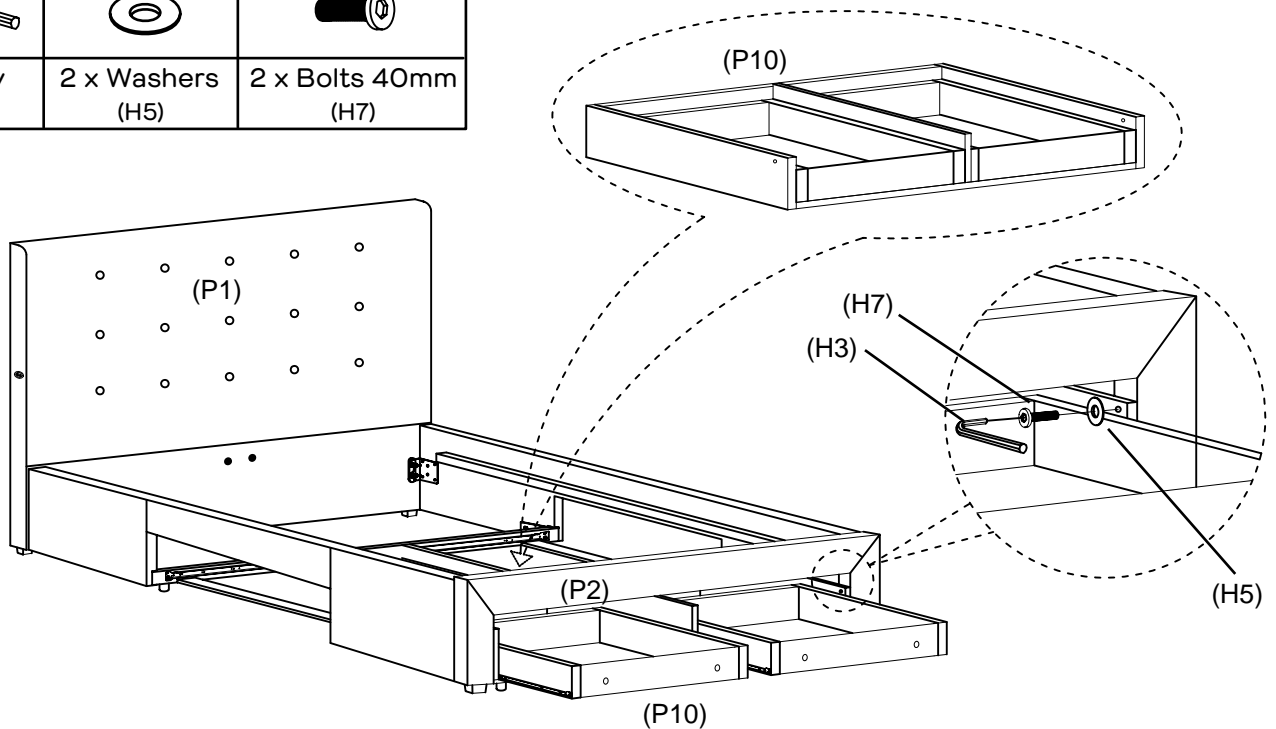

You will need		
		
Allen key (H3)	2 x Washers (H5)	2 x Bolts 40mm (H7)

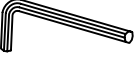

Please place Footboard Drawer(P10) into the inner space as shown.

Please pull out the drawers to be half, then attach the Footboard Drawer(P10) to Footboard(P2) with 2 x Washers(H5) and 2 x Bolts(H7) by using Allen Key(H3).

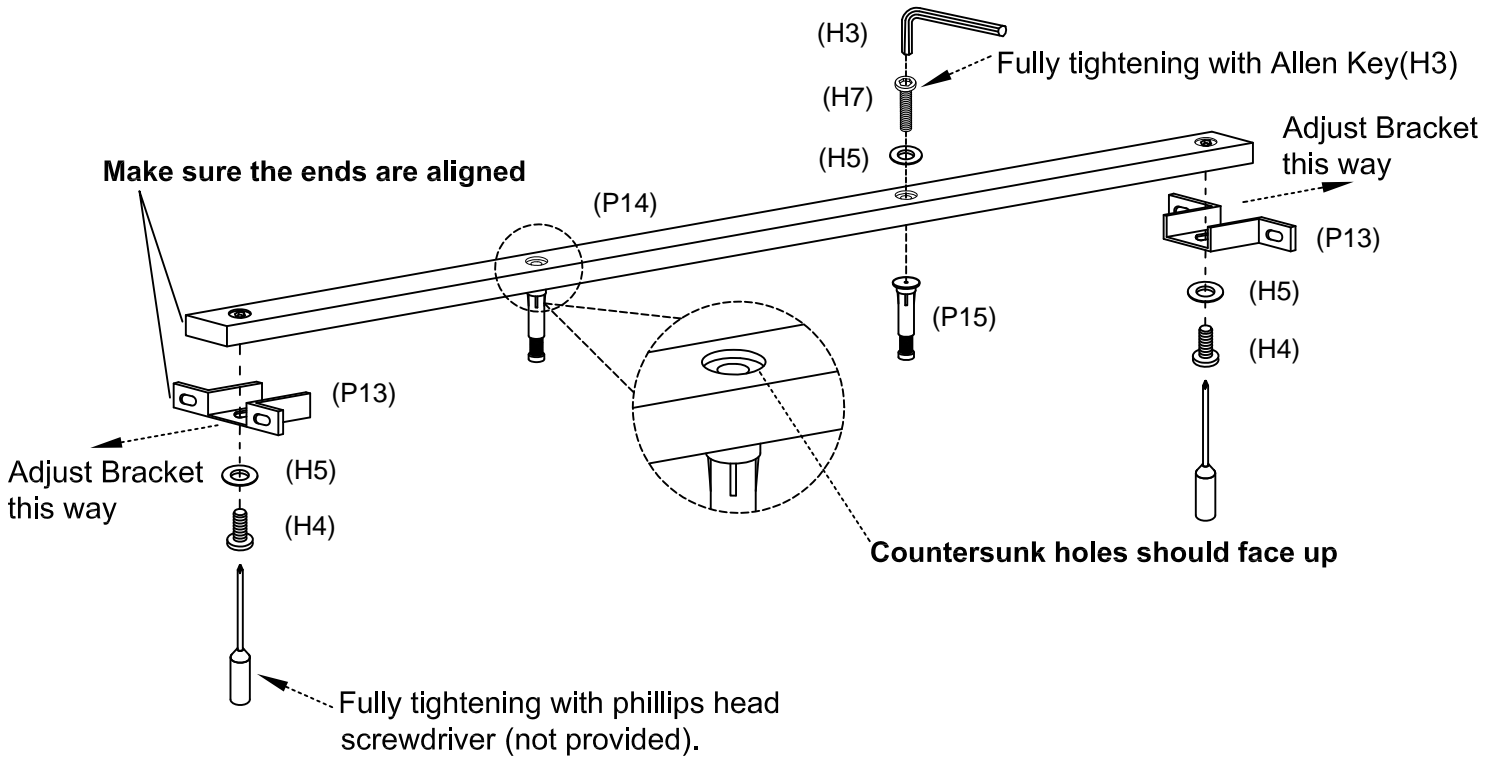

Step 9

You will need				
				
Allen key (H3)	2 x Bolt 20mm (H4)	4 x Washers (H5)	2 x Bolt 40mm (H7)	Phillips head screwdriver (not provided)



Attach the Support Leg(P15) to the Center Rail(P14) by using 2 x Bolt(H7) and 2 x Washer(H5). Attach 2 x Bracket(P13) to the Center Rail(P14) by using 2 x Bolt(H4) and 2 x Washer(H5) as shown.

Step 10

You will need		
		
4 x Bolts 20mm (H4)	4 x Washers (H5)	Phillips head screwdriver (not provided)

You must use.

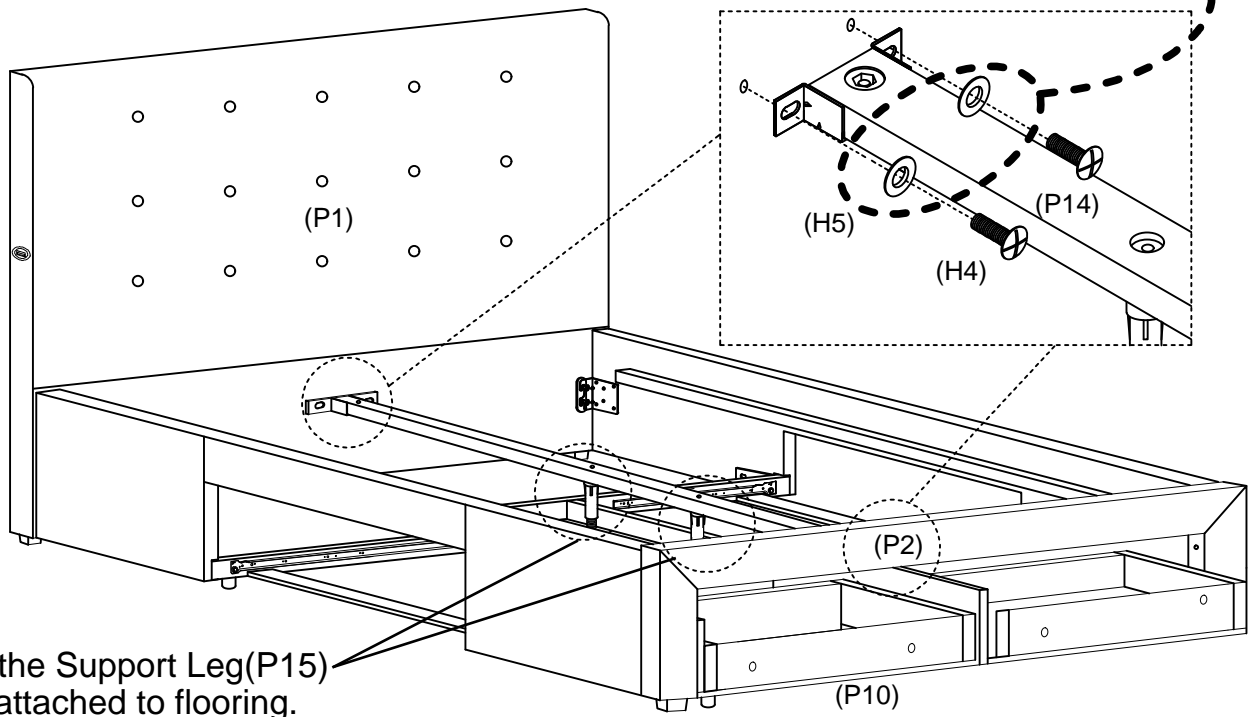

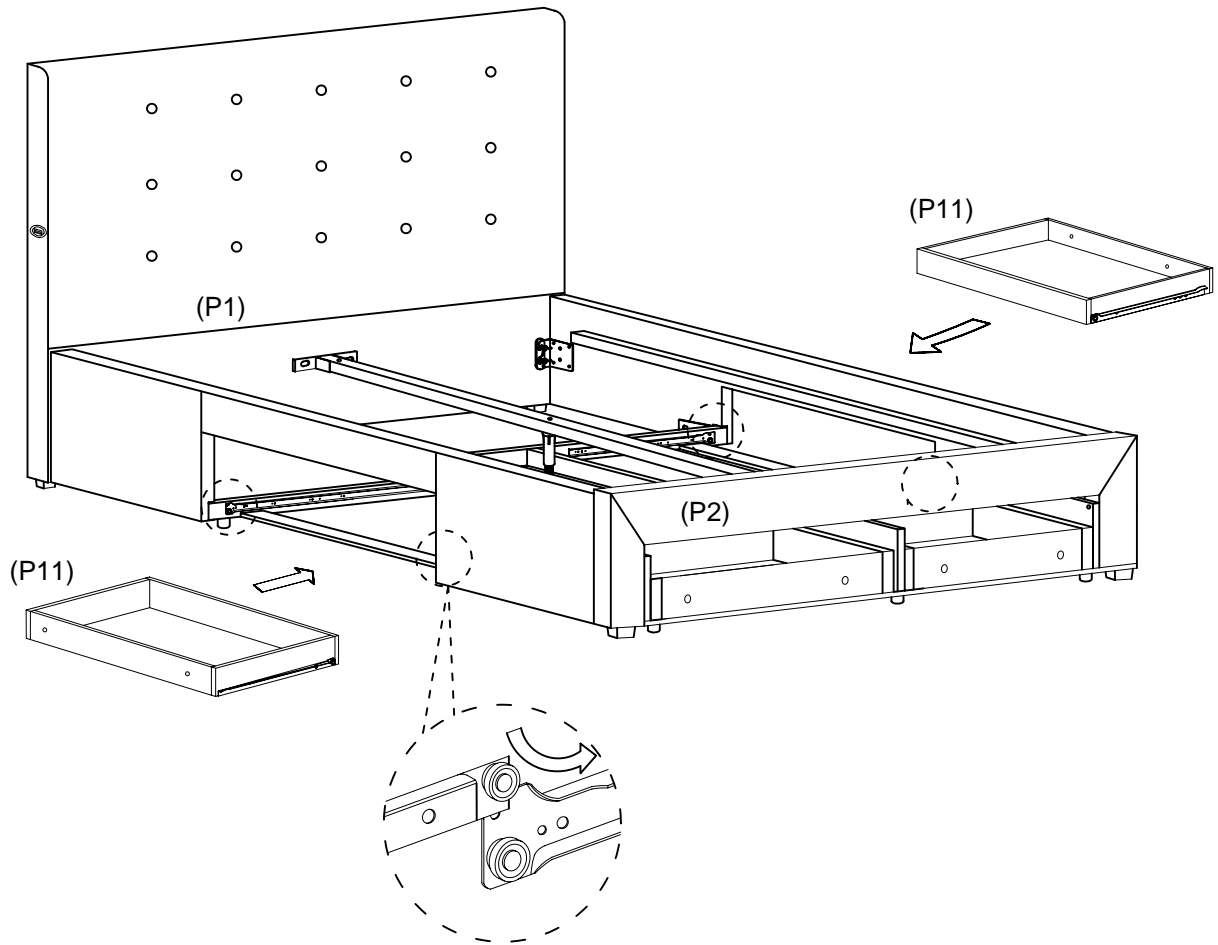

Slot the centre rail(P14) into the headboard(P1) and footboard(P2)
Rotate 4 x bolts(H4) and 4 x washers(H5) by using phillips head screwdriver
to the headboard(P1) and footboard(P2). Fully tighten all the bolts(H4).

Step 11



Attach the two Side Rail Drawer(P11) to the Runners Rail(P5) as shown.

Step 12

You will need		
		
8 x Washers (H5)	8 x Bolts 30mm (H8)	Phillips head screwdriver (not provided)

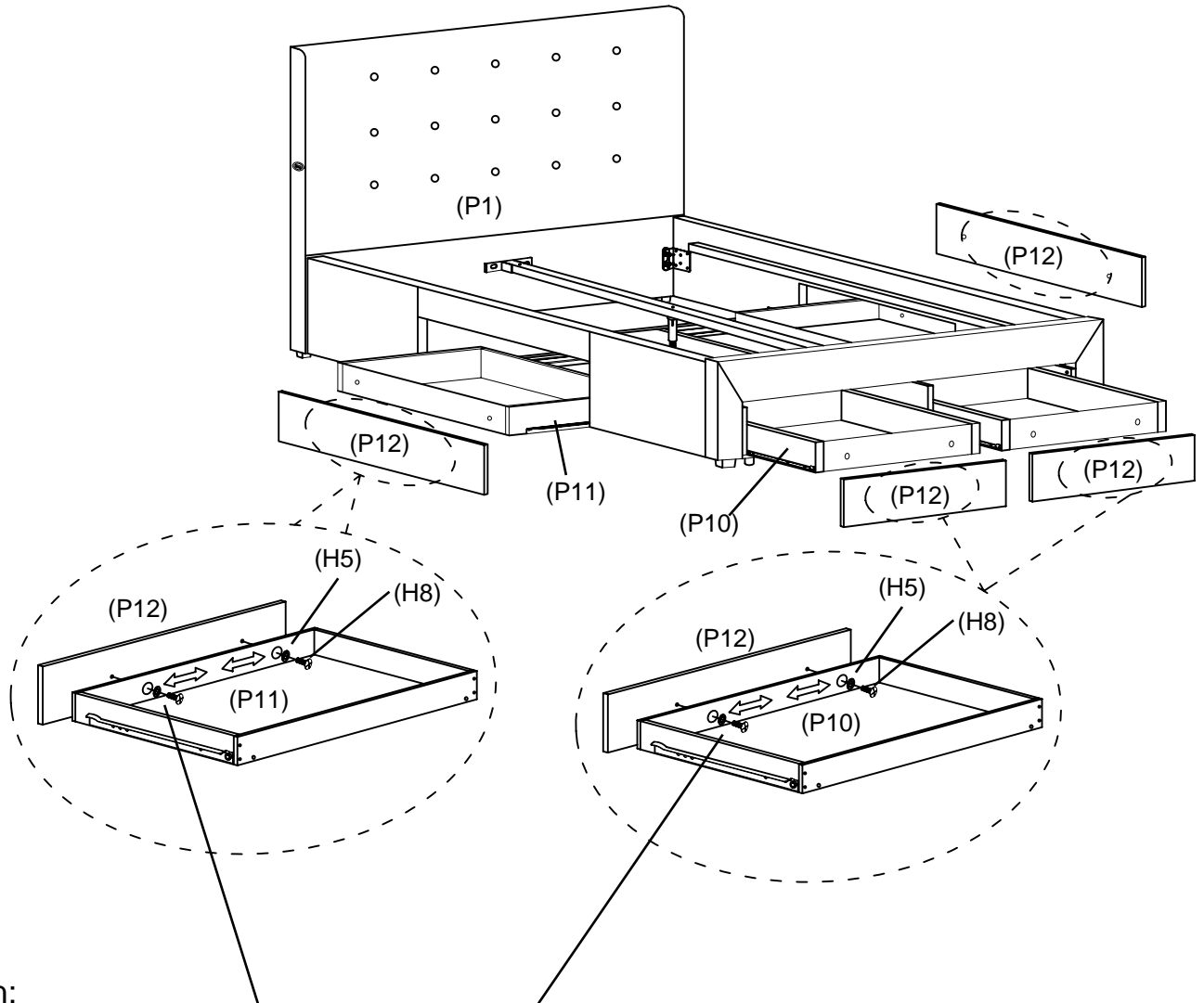



Attention:

The drilled hole is a little bigger than the bolts, when assembling, the bolts can be adjusted.

Attach Drawer Boards(P12)
to the Side Rail Drawer(P11) with
4 x Bolts(H8) and 4 x Washers(H5).

Attach Drawer Boards(P12)
to the Footboard Drawer(P10) with
4 x Bolts(H8) and 4 x Washers(H5).

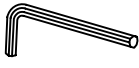
Step 13

You will need	
	
Allen key (H3)	42 x Small Screws (H9)
	
Phillips head screwdriver (not provided)	

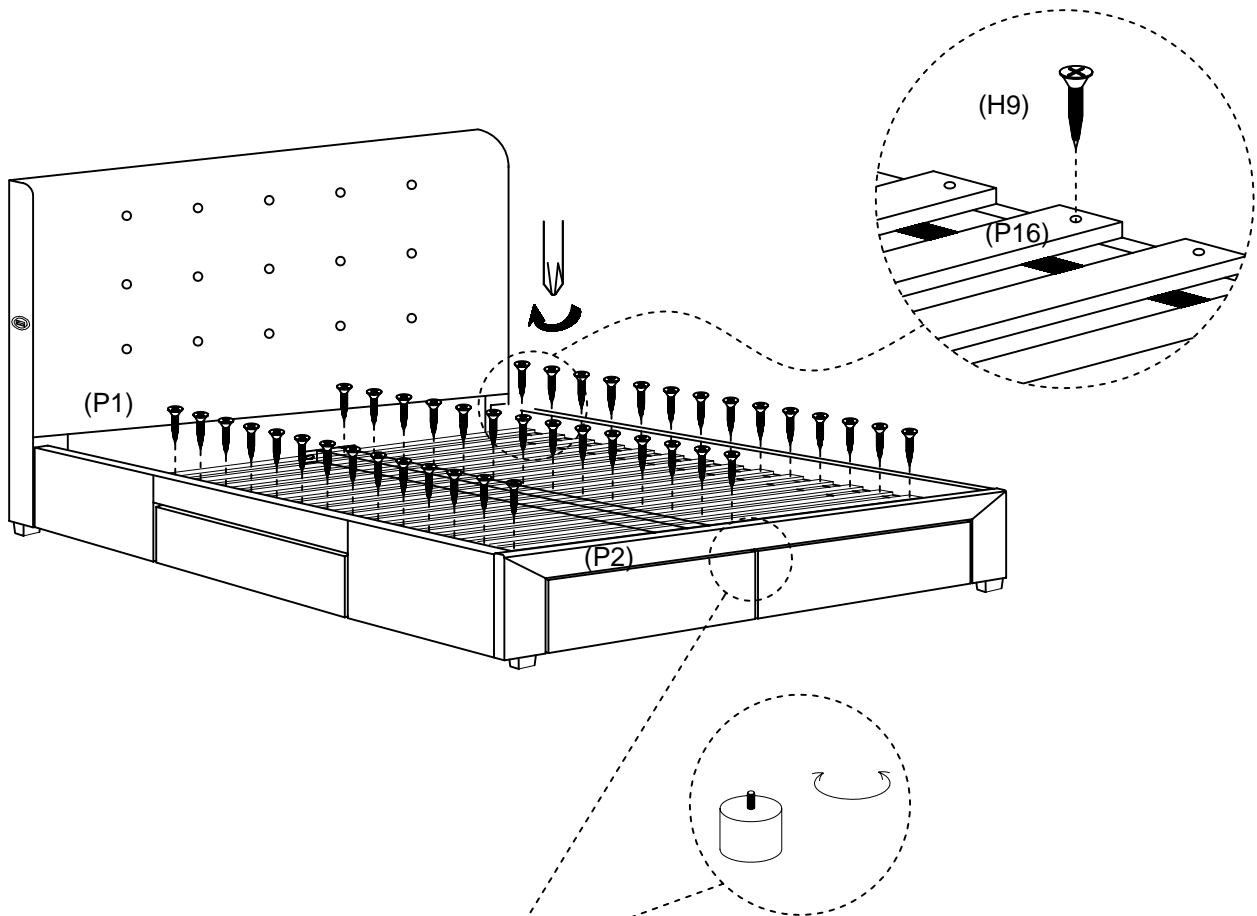
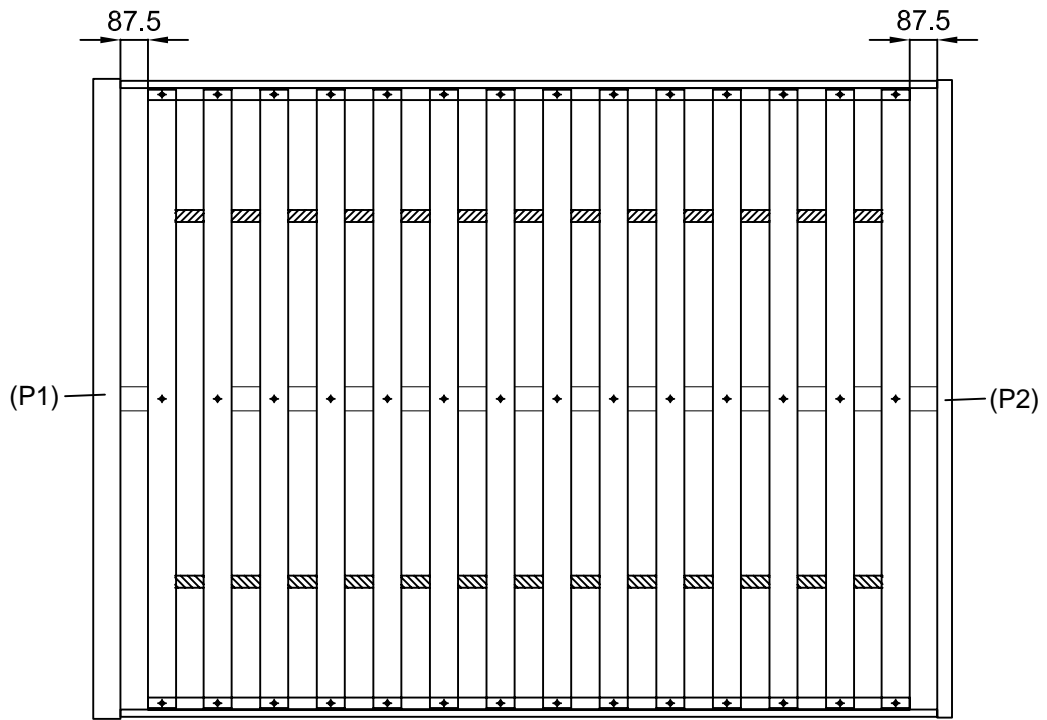

The gap between Drawer Boards(P12) and Footboard(P2) is available to be adjusted by the bottom middle leg of Footboard Drawer(P10).

Make sure the inner space is square.

Then assemble all the Slats(P16) down by using 42 x Small Screws(H9).

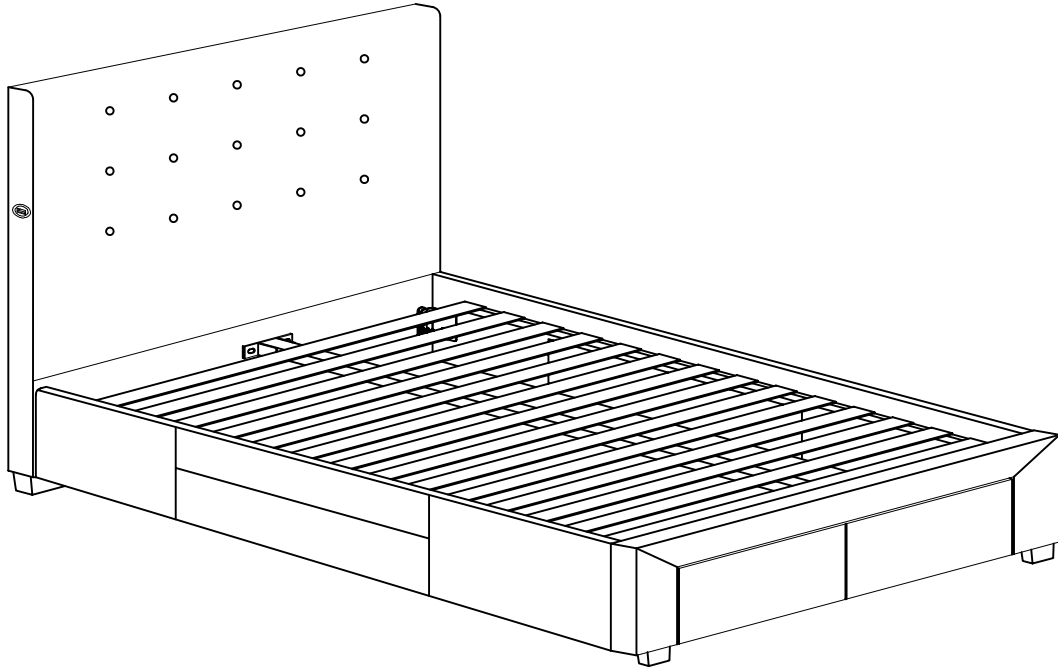

Job Complete

In the interest of our environment please dispose of all packaging thoughtfully.